

PARTS AND SERVICE MANUAL

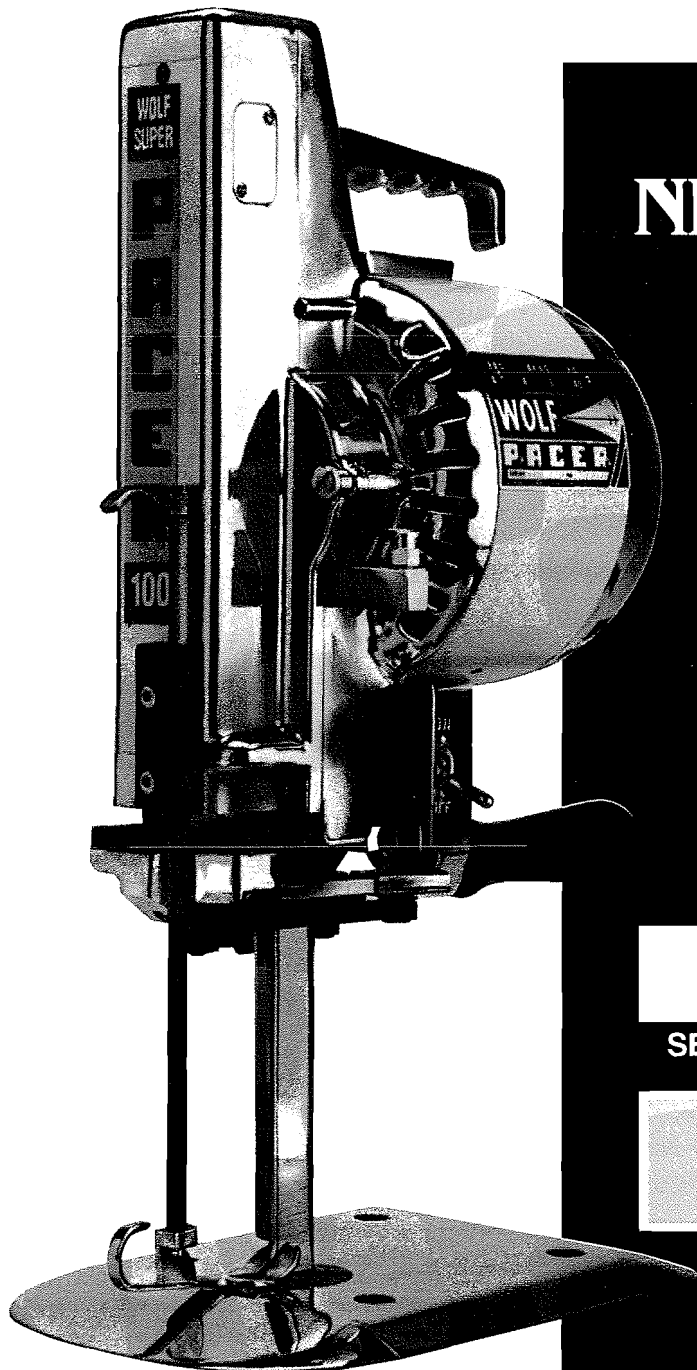

NEW PACER 100

Sharpener Series
VI, VII, VIII, X & XI

34th Edition
PUBLISHED
June 2005

SERIAL NUMBER OF YOUR WOLF PACER

WARNING: READ INSTRUCTIONS ON
PAGES 1 AND 2 BEFORE OPERATING
OR HANDLING THIS MACHINE.

From the library of: Diamond Needle Corp

WOLF®

1st/Since 1888

5570 CREEK ROAD, CINCINNATI, OHIO 45242 / U.S.A.

TOLL FREE 1-800-543-WOLF

Phone: 513-791-5194 / FAX 513-791-0925

e-mail: info@wolfmachine.com • Web Site: www.wolfmachine.com

C·O·N·T·E·N·T·S

SECTION I - SERVICE MANUAL	1 thru 14
Instructions for a NEW Pacer	1, 2
Maintenance for All Models	3-6
Installation of Knife.....	4
Maintenance of Knife and Standard.....	4
Knife and Crosshead Alignment	4
Lubrication	5
Adjustment of Guide	6
Changing the Rubber Drive	7
Care of Rollers and Retainers	7
Removal of the Follower	7
Maintenance for Stone Sharpener	8-11
When Sharpening a New Knife	8
Emery Wheel Applications.....	8
Changing the Grinding Wheels	9
How to Disassemble the Sharpener	9
Proper Adjustment of the Sharpener	10
Adjustment of the Presser Foot Lock Assembly	11
Maintenance of Belt Sharpener	12-14
When Sharpening a New Knife	12
Changing Emery Belts.....	12
Emery Belt Applications.....	12
Proper Adjustment of Sharpener	13
Adjustment of Presser Foot Lock Assembly	14
How to Disassemble Sharpener	14
 SECTION II - PARTS MANUAL	 15 thru 38
Reference Page	15
Drive Assembly & Numbers	16, 17
Motor, Connector Box Assemblies & Numbers	18
Motor, Cord Connectors Assemblies & Numbers	19
Motor, Connector Box Assemblies & Numbers for Pacer 100	20
Motor, Cord Connectors Assemblies & Numbers for Pacer 100 ..	21
Standard, Insert, Footplate Assemblies & Numbers	22-25
Stone Sharpener & Numbers	26, 27
Belt Sharpener & Numbers.....	28, 29
Backplate Assembly & Numbers	30, 31
Series X Stone Sharpener & Numbers	32
Knives	33
Accessories	
Pacer Guard	34
Lamp, Clamp, etc.	34
Slider Oiler & Installation Instructions	35
Twin Flow Wetter & Installation Instructions.....	36
Tools, Lubricants & Cleaning Agents	37
Straight Knife Specifications / Guarantee	38

WOLF STRAIGHT KNIFE CLOTH CUTTING MACHINES

Wolf Machine offers two basic machine models in the Straight Knife Cloth Cutting Machines: The Stone Sharpener Series and The Belt Sharpener Series. Both series are available in 5", 6", 7", 8", 10" and 14" models. All have the same great quality engineering that Wolf has built its reputation on!

Belt Sharpened Series VIII & XI

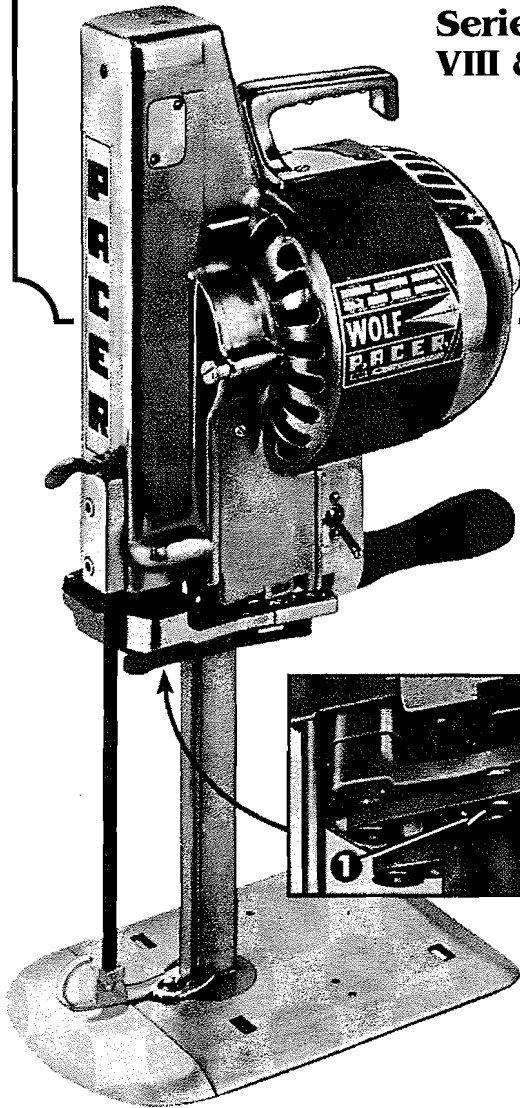

The Wolf Belt Sharpened Series has a unique emery belt sharpening head which produces an exceptionally fine honed, slick blade edge that is superior for cutting finely textured materials and for special trimming. Emery belts graded fine, medium, coarse and very coarse are used to change the blade edge for cutting medium to coarse or hard fabrics. A simplified bevel adjustment control provides easy positive knife bevel selection. (See #1 above and page 13). Emery belt replacement is accomplished in seconds with a finger-tip quick-change mechanism (See #2 above & page 12).

Stone Sharpened Series VI, VII & X

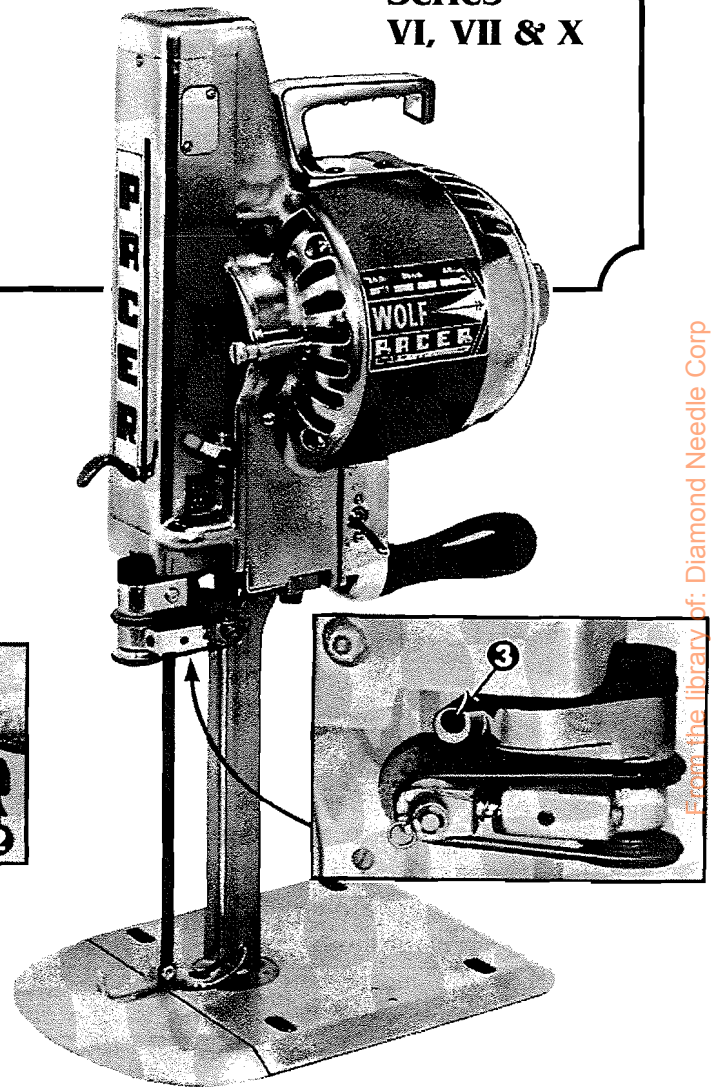

The Wolf Stone Sharpened Series is a stone sharpened straight knife which is the most versatile and economical machine for a wide variety of fabric cutting. Tension can be adjusted to balance emery wheel pressure with extreme sensitivity (See #3 above and pages 8 and 9). The mechanism is self locking to maintain positive adjustment.

Millimeter Equivalents, Machines Sizes:
5" = 127mm; 6" = 152mm; 7" = 178mm;
8" = 203mm; 10" = 254mm; 14" = 356mm.

INSTRUCTIONS FOR A NEW PACER

CAUTION: READ PAGES 2 & 3 BEFORE OPERATING THIS MACHINE.

This Parts and Service Manual has been supplied to enable you to take the best possible care of your new machine. By carefully following the service instructions contained in this manual, you will be assured of the best performance with minimum maintenance of your Wolf Pacer. Corrections of major maintenance problems should be made at the factory or in the field by a qualified, factory-trained maintenance representative.

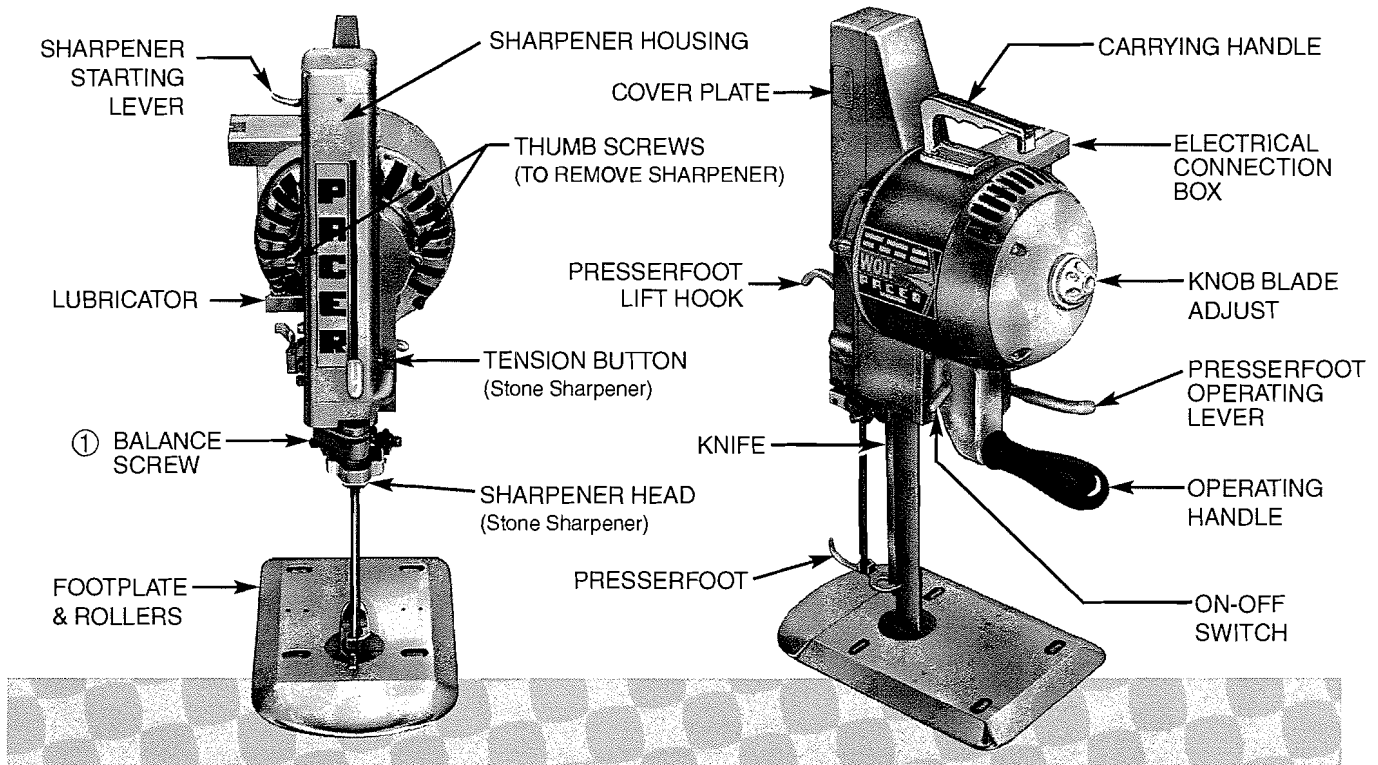

From the library of: Diamond Needle Corp

When your new Pacer is first put into service, allow the machine to come to **room temperature**. Before the machine is plugged in make sure that the Motor rotates freely and the Knife is properly set, (turn the Rotor Knob at the rear of the machine - see above). The Knife should not strike the table when Knob is rotated. **Caution:** The Knife is factory sharpened and ready to use on a new machine. Also check to see if the Crosshead

slides freely between the Guide Plates by unscrewing the two thumb screws (see above) on the front of the machine and removing the sharpener and turning the Rotor Knob. If the Crosshead does not slide freely see page 6 for, Adjustment of the Guides. Note: Do not oil graphite Crosshead Guides. (Heavy duty steel require lubrication).

WARNING

THIS IS A HAZARDOUS TYPE OF MACHINERY AND SHOULD BE USED WITH CARE.

Always disconnect the electrical connector before attempting to work on this machine. For operator safety: 1) Keep the Presserfoot down when machine is not in use; 2) Keep Presserfoot as low as possible when cutting; 3) Never place hands between Presserfoot Rod and Knife or in the path of the

Sharpener while the machine is running; 4) Never use a Knife with a broken or improper guard; 5) Remove all loose fitting jewelry; 6) Do not wear loose or baggy fitting clothing; and 7) Persons with long hair should cover or pull it back. We also recommend the use of steel gloves for maximum safety.

THE ELECTRICAL CONNECTOR

The Connector Box on the Pacer is drilled for both single and three phase cord coupling (as shown below). Wolf (as well as many other) plugs will fit by using smaller pins available from the factory. If you install connection block pins, be sure that they are tight, and that the grounding support knob on the cord is used.

Before placing three phase machines into service be positive that the motor will rotate in the direction indicated by the arrow stamped on the rear

head of the motor. To check the direction of rotation make a flash contact with the switch turned on. If the rotation is not in the correct direction, it can be reversed by reversing any two of the circuit lines.

If the motor is allowed to run in the wrong direction, the crank will unscrew and damage the machine. Single phase motors automatically turn in the proper direction.

Wolf "Pacer" Connection Block Diagram of Post Combinations for various Cord Coupling Plugs.

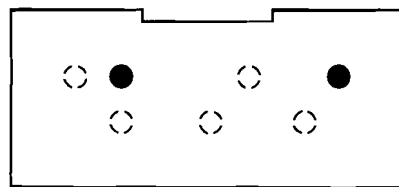

WOLF 1 PHASE

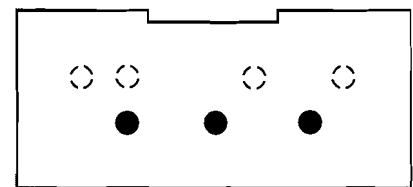

WOLF 3 PHASE

To assure best performance, use only Wolf replacement parts.

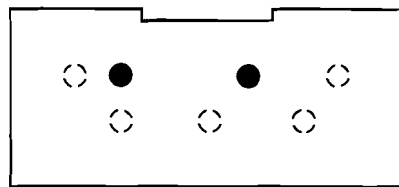

EASTMAN 1 PHASE

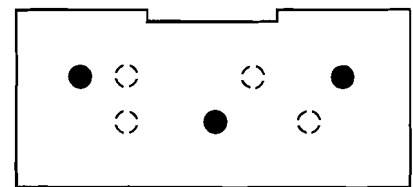

EASTMAN 3 PHASE

STRAIGHT KNIFE SPEEDS

STROKE	60 CYCLE		50 CYCLE		
	3450 R.P.M.	1725 R.P.M.	2900 R.P.M.	1450 R.P.M.	
	INCHES/MIN.	INCHES/MIN.	STROKES	INCHES/MIN.	INCHES/MIN.
1-1/4"	9,000	4,500	1-1/4"	7,250	3,625
1-3/8"	9,900	4,950	1-3/8"	7,974	3,987
1-1/2"	10,800	5,400	1-1/2"	8,700	4,350
1-3/4"	12,600	6,300	1-3/4"	10,150	5,075

MACHINE STROKES

1-1/4"	Short	32mm
1-3/8"	Medium	35mm
1-1/2"	Long	38mm
1-3/4"	Extra Long	44mm

MACHINE SIZES

5"	127mm	8"	203mm
6"	152mm	10"	254mm
7"	178mm	14"	356mm

MAINTENANCE FOR ALL MODELS

PAGES 4, 5, 6 & 7

INSTALLATION OF KNIFE

Whenever it is necessary to remove the knife from the machine, *disconnect the electricity* and lay machine on its side with the name plate up. Insert Knife Bolt Wrench (#1092000), loosen the Knife Bolt (#1064050, see #4 below) and remove the knife through

the bottom of the Footplate. It is not necessary to remove the sharpener to remove the Knife.

To replace the knife, place selvage over the sharp edge of the Knife to protect your hand and force the Knife up and back in the Knife slot. When the Knife is properly seated, tighten the Knife Bolt. The machine must be in an upright position when the Knife Bolt is tightened to prevent binding. Before sharpening; see index "**When Sharpening a New Knife**", for your particular series machine. Read thoroughly and follow instructions carefully.

MAINTENANCE OF KNIFE STANDARD

Maintenance of the Knife and Standard, while simple, is important to the proper functioning of the machine. After 40 running hours or as necessary depending on materials cut or at least weekly, the knife slot in the standard should be cleaned free of lint and dirt. If this is neglected the standard can

become packed, which causes heating and binding of the Knife. To clean the Standard knife slot, remove the Knife and clean the slot with the Slot Cleaner (#2101200). Never operate the machine with worn inserts in the standard. (See page 37 for tools.

KNIFE AND CROSSHEAD ALIGNMENT

Check alignment between the knife slot, standard and crosshead whenever guides are replaced or adjusted. To do this place a new Straight Knife in the slot, and slide the Knife up over the Knife Bolt Tang (#1 at right) on the Crosshead with the Knife Bolt (#4) removed. The Knife should not bind or be set away from the tang. To adjust, if need be, slightly loosen the two 3/8" bolts at the top of the Standard (#2) and tap the Standard at its top (#3) with a hammer until you get proper alignment. When properly aligned, re-tighten bolts.

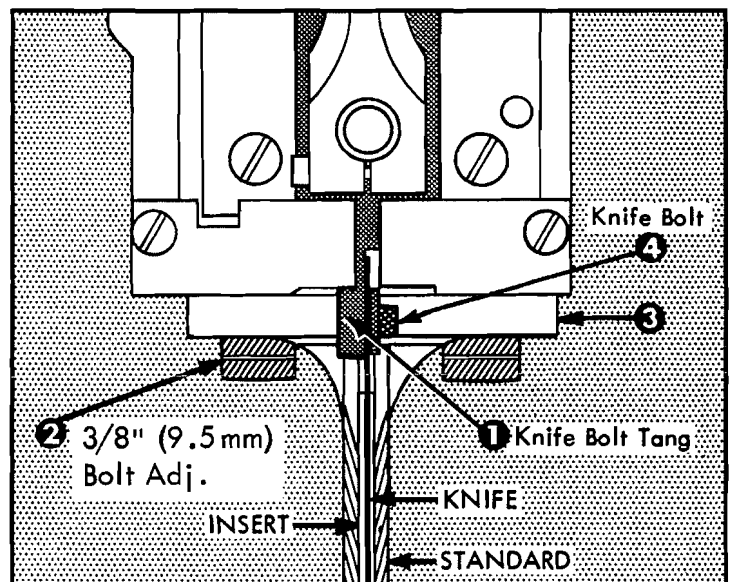

LUBRICATION

Lubrication of this machine is easily accomplished. Every eight hours of operation add three to five drops of a good grade of 30 weight lubricating oil to Lubricator (#1 below). Do not over lubricate. NEVER OIL GRAPHITE CROSSHEAD GUIDES. (Heavy duty steel guides require lubrication.) If oil should get on Graphite Guides, they will become gummy and stall the cutter. Should this happen, clean the guides thoroughly by flushing with Keep-M-Kleen solution. Guides or Crosshead do not have to be removed from machine during cleaning. Add oil to Crosshead wick after cleaning.

A few drops of oil should be placed on moving parts and gears periodically, or after they have been cleaned in solution. Excess oil on grinder parts collects emery and will cause faster wear and poor grinding. DO NOT OIL THE ROLLERS IN THE FOOTPLATE.

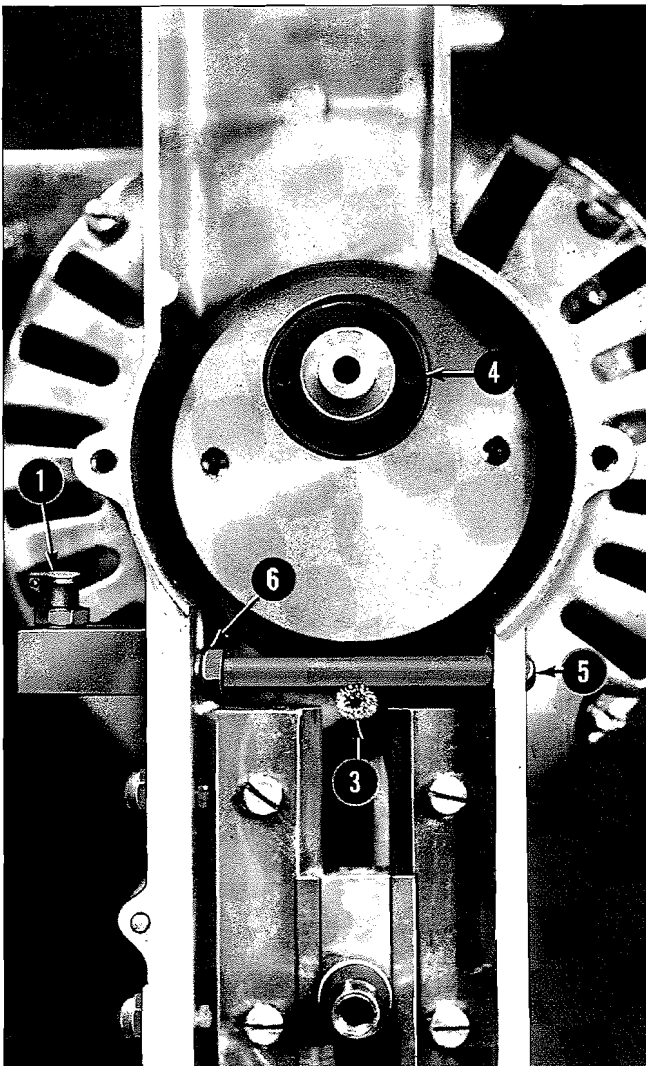

The center wick (#3 at left) should be soft and come into contact with the Crosshead Wick, when the Crosshead is at the top of the stroke. Replace the wicks if they are worn or broken. To replace wick, remove the retaining screw (#5 at left) while holding the lubricator steady with your hand. The feeder tube may now be pulled out. To take off entire oiler assembly, use an open end wrench to remove the oiler tube nut (#6 at left). This is a right hand thread.

All ball bearings in this machine are sealed, pre-lubricated bearings. If the crank bearing needs to be greased or replaced, remove Connecting Rod (see page 6, Fig. A) then remove the Bearing Locknut (#4 at left) with Pin Wrench (#1091060). The bearing can now be pulled from the Crank with the Crank Pin Puller (not illustrated). Use a good grade of high speed bearing grease available from the factory. Bearings should be replaced only with the bearing knockers sold from Wolf. For accessories, lubricants and tools, see page 37.

ADJUSTMENT OF GUIDES

The Guide Plate and Crosshead can be adjusted if they become noisy or freeze. If the Guides are scored or marred it will be necessary to replace them. To adjust the Guides, remove the Sharpener Housing Assembly. Remove the Connecting Rod (#1 in Fig. A) by loosening the two Connecting Rod screws (#2 in Fig. A). Loosen two screws #9900824 (#1 in Fig. B) and retighten to a snug fit, to keep the Guides from cocking while adjusting. Loosen Locknut #1062200 (#2 in Fig. B) and slowly turn adjusting set screws #9901810 in direction needed for more or less play in the Guides. After getting proper fit (the Crosshead [#4 in Fig. B] should be free but with no side play) tighten screws #9900824. Tighten Locknut #1062200 while holding Slotted Set screw with screw driver to keep from turning. Replace the Connecting Rod, making sure that the rod is tight against the Crosshead Wear Plate (#5 in Fig. B) with the Wrist Pin drawn forward to apply pressure against the Spring Washer located between Crosshead and head of Wrist Pin. When properly positioned, tighten the Connecting Rod screws (#2 in Fig. A)

Additional adjusting of Guide Plate is done while machine is running. Adjust Guide inward until machine runs with minimum amount of noise, then back out slightly and lock in place. When new Guides are installed this adjustment will have to be made several times until the Guides have developed a shiny black glaze on their surface. When proper adjustment is made, tighten the Locking screws (#1 in Fig. B).

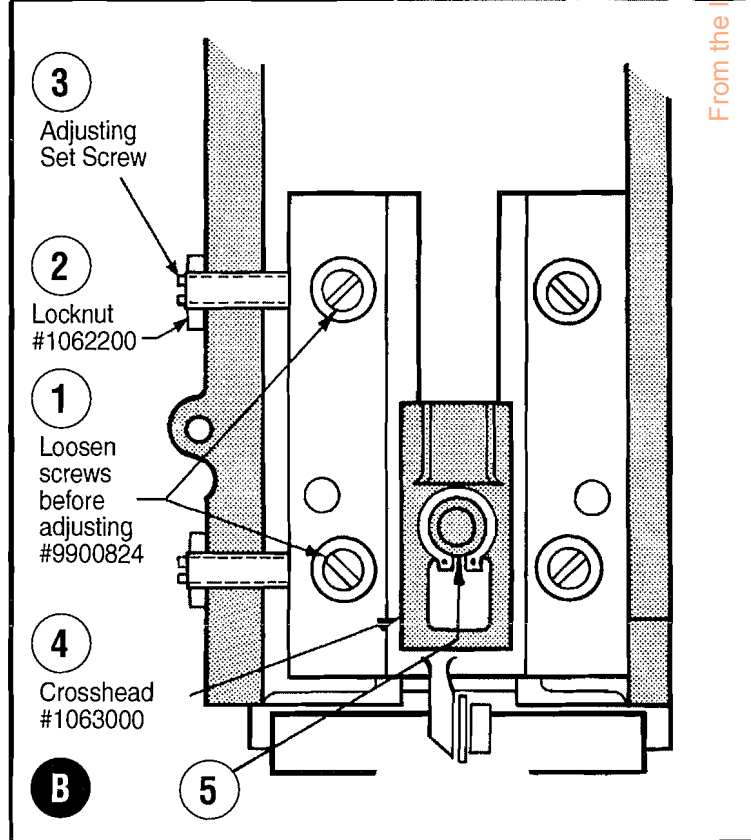
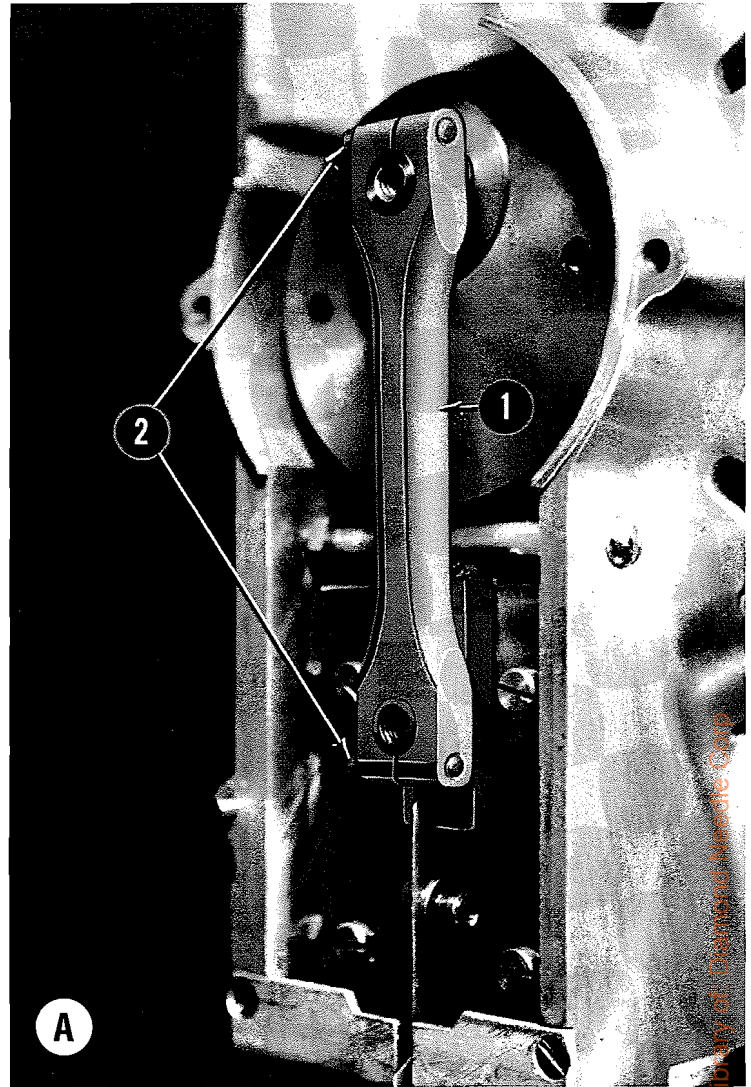

From the Library of the University of Kentucky

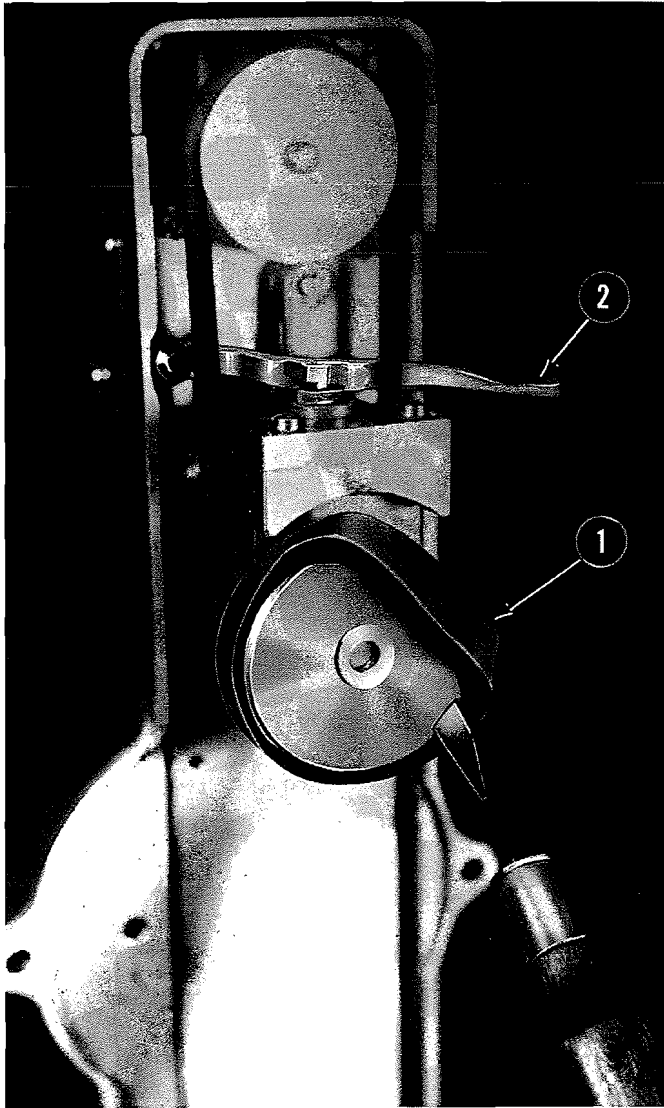

CHANGING THE RUBBER DRIVE

Occasionally the Rubber Drive (#1 in Fig. C) on the back of the Sharpener will need replacing. This is easily accomplished. Remove the worn Rubber Tire by cutting it with a knife.

To replace the Rubber Drive, engage the starting lever (#2 in Fig. C), place the new tire in the groove and stretch it over the rim with a screw driver.

NOTE: On newer models this is one piece. Order Part No. 1217550.

CARE OF ROLLERS & RETAINERS

The Rollers and Retainers on the Footplate should be removed and cleaned regularly. An air hose is ideal for this. All dirt and lint should be removed. Do not oil the rollers.

A clean machine will always function better. It is suggested that lint and dirt should be blown out of the machine regularly with an air hose.

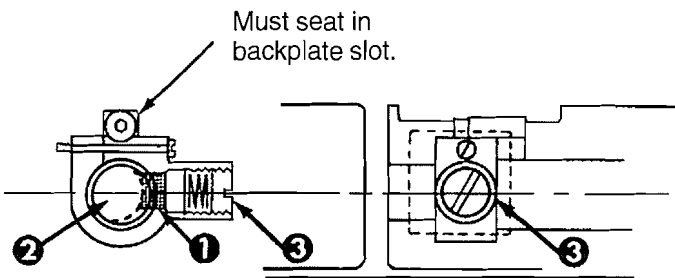

Cover Plate must be removed from opening inside of sharpener housing.

REMOVAL OF THE FOLLOWER

When removing or installing the Follower (#1 at left) be sure it is properly seated in the Reversing Drive Shaft (#2). When replacing the Follower Retaining Nut (#3), turn the nut down until it is tight. Sharpener must be in up position in order to get to the Follower through the side opening. A tool is available to help remove and replace the Follower. If desired order #2107600.

MAINTENANCE STONE SHARPENER SERIES ONLY

PAGES 8, 9, 10 & 11

WHEN SHARPENING A NEW KNIFE

To engage sharpener, press starting lever down as shown in the picture on page 7, Fig. C, #2. When first sharpening a new replacement knife, depress tension button (#3 at right) for two or three strokes of the sharpener and then release the button. Allow the sharpener to make two or three additional strokes without the tension button depressed. The new knife should be ready for cutting. **DEPRESS THE TENSION BUTTON ONLY WHEN SHARPENING A NEW KNIFE.** A burr will result from over sharpening. It is advisable to check new knives for burrs on bottom. Remove burr with hand stone if they exist.

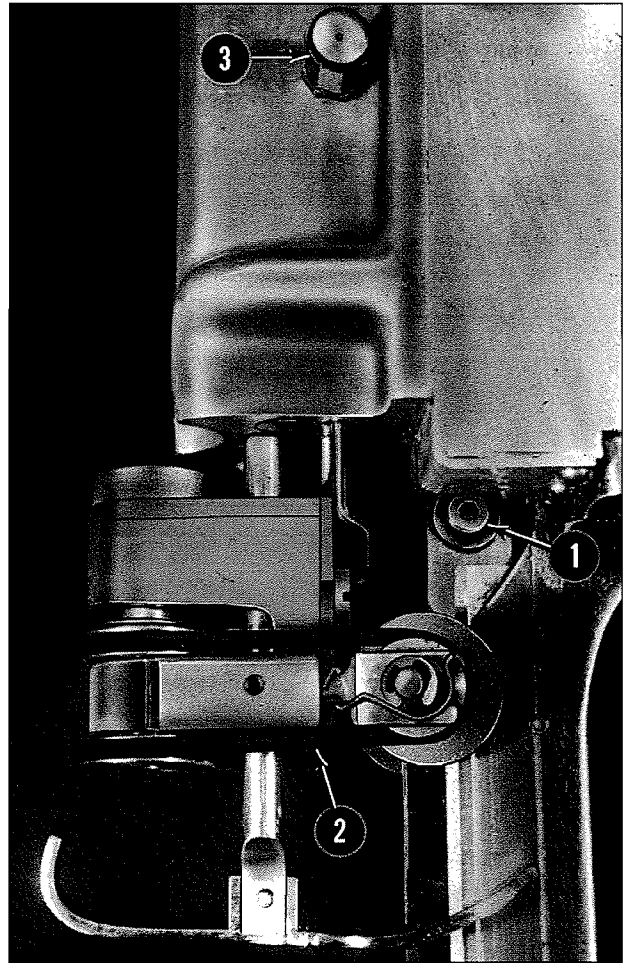

From the library of: Diamond Needle Corp

EMERY WHEEL APPLICATIONS

Most goods use two #1280100 - 120 grit emery wheels.

Coarse material such as denim use two #1280000 - 80 grit emery wheels.

For all wave style and notched style blades use two #1280000 - 80 grit emery wheels.

**TO ASSURE BEST PERFORMANCE
USE ONLY WOLF REPLACEMENT PARTS,
KNIVES AND SHARPENING STONES.**

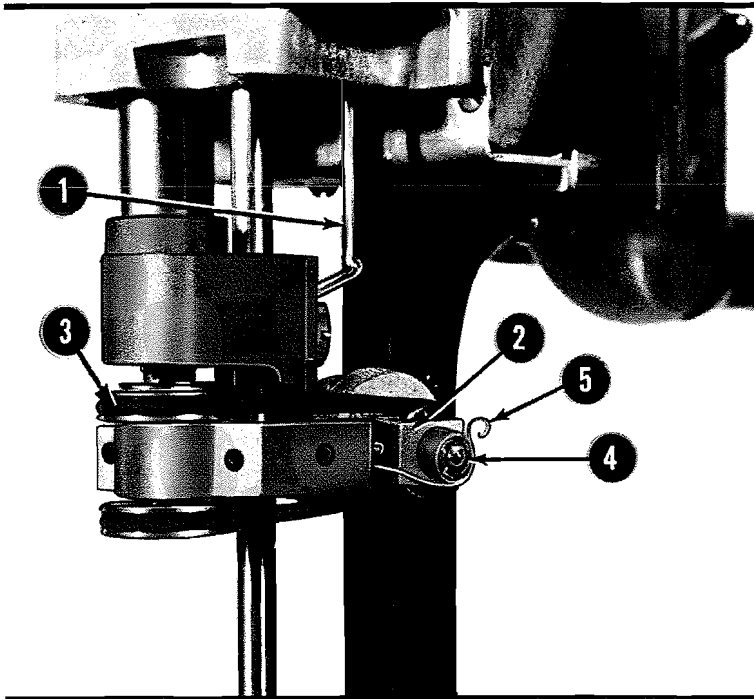

TO CLEAN OR CHANGE THE GRINDING WHEELS remove the grinder belt (#3 at left). Turn spring (#5 at left) to release grinding wheel shaft assembly. Remove the grinding wheel and shaft assembly (#4) by sliding it backward out of the support arm (#2). The wheels may now be changed by removing the mounting screw and washer from the inset face of the wheel.

To clean the wheels, use the wire brush supplied with the machine and spray with Wolf's Keep-M-Kleen emery wheel cleaner. Also, use Keep-M-Kleen to remove oil and dirt from the tension rod (#1 at left) and all the grinder head parts. Before wheels and shafts are installed back in the support arms, make sure they turn freely.

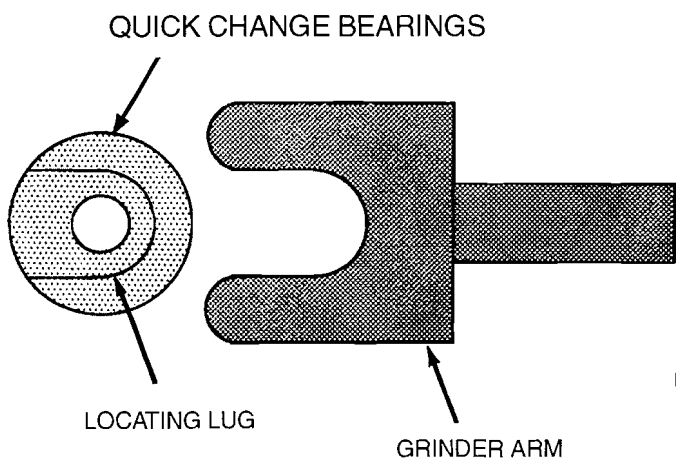

THE QUICK CHANGE BEARINGS must be placed in the grinder wheel support arms with the locating lug out. If it is inserted with the lug in the wrong position, it will cause the grinding wheel to grind the standard instead of the knife. It is best to run the sharpener half way down the knife, and then moving it horizontally back and forth by hand, observe the clearance between the standard and grinding wheels before running the machine.

When replacing the belt, be sure it is properly seated in the pulleys. When a new belt is placed on the machine the balance of the grinders should be checked as directed on page 10.

HOW TO DISASSEMBLE A STONE SHARPENED SERIES MACHINE

To repair or replace parts within the sharpener, remove two thumb screws (#1200700, page 15) and remove front housing assembly.

(Exploded view drawing – see pgs. 26 & 30.)

1. To remove backplate, remove top belt.
2. Remove backplate screws (4).
3. Remove screws (2) and cap of front housing.
4. Remove screws (2) and cover plate.

5. Remove tension cap, spring and shoe (Fig. E, page 10).
6. Remove follower screw, spring and follower. Loosen clamp screw. (See bottom of page 7.)
7. Remove Locknut #9902308, worm wheel gear #1230000 and key #1231000. (See page 26.)
8. By sliding shaft down, the complete reversing drive assembly can then be removed, complete with stone sharpening head.

PROPER ADJUSTMENTS OF SHARPENER

Proper adjustment and maintenance of the sharpener gives longer and better knife service. If the sharpener doesn't operate properly and tends to grind more on one side of the knife than the other, first check to be sure that the grinding wheels are not dirty or worn. If the parts are dirty, clean them thoroughly. Check the bottom belt (#2 on page 8) for proper tension and wear by comparing it with a new belt.

If this doesn't remedy the situation it can be corrected by adjusting the emerys. To check the grinder adjustment, remove the cap and spring (#3 on page 8) from the tension assembly. With the machine running, operate the sharpener and observe from the rear of the machine, the position of the grinding wheels relative to the knife or standard.

To adjust the emery wheel balance of the sharpener, first back out the balance screw (#3 on page 1) and, while running the sharpener with tension cap removed, observe the location of the emery wheels in relationship to the knife. The gap between the wheel and the knife will be greater on the side of the knife farthest from the adjusting screw. Next, very slowly, 1/8 turn at a time, tighten the balancing screw. The gap on the balance spring side will slowly close. When gap on both sides of knife is same, reassemble the tension cap assembly (Fig. E). Do not tighten balance screw more than required to equalize wheel to knife gap on both sides. The emery wheel balancer can also be adjusted by examining the sharpener of the blade. If the side of the blade farthest from the balance adjusting screw is being ground too much, tighten the screw until an even grind on both sides is achieved. If the side of the blade closest to the adjusting screw is ground to much, the balance adjusting screw should be loosened slightly.

Note: If the sharpener doesn't operate properly after all of the above steps have been taken, it is probable that #1271100 Fibre

When properly set, the grinding wheels are centered with the same distance between the knife and grinding wheel on each side. If only one wheel is grinding, determine which wheel it is and then stop the machine.

Be sure to remove tension cap before attempting to adjust sharpener.

D

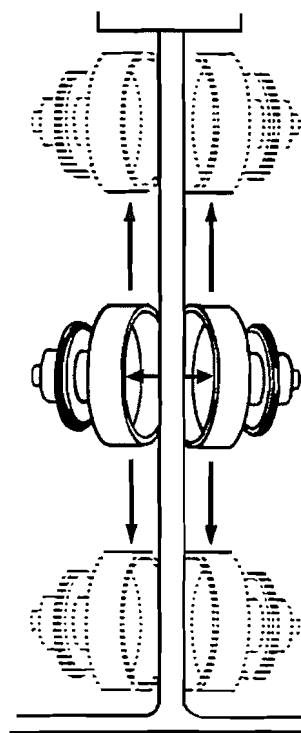

Below shows the proper reassembly of the tension adjustment spring components.

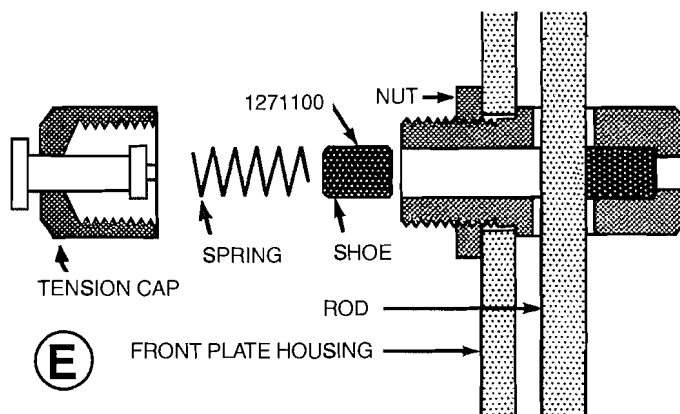

Since the grinding wheels will not be centered when the machine is not operating, it must be running when checking adjustment.

Shoe (shown in Fig. E) has become clogged with oil and is slipping or vibrating against the tension rod unevenly. IT IS NECESSARY TO KEEP THIS SHOE CLEAN ... WHEN IT BECOMES LOADED WITH OIL IT MUST BE REPLACED.

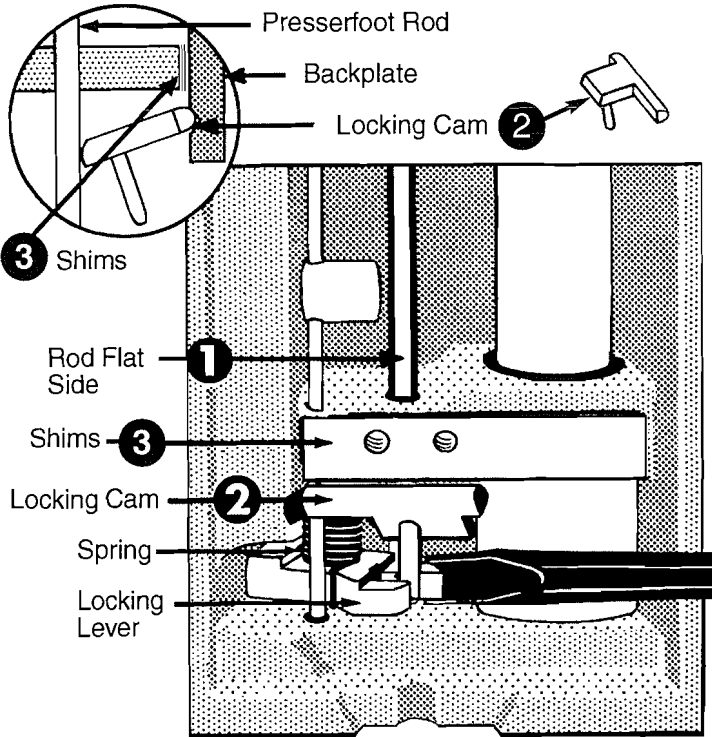

ADJUSTMENT OF PRESSERFOOT LOCK ASSEMBLY

NOTE:

The Presserfoot Lock Assembly needs to be adjusted ONLY if the Presserfoot Rod is not holding.

The Presserfoot Lock and Backplate Assembly sketch and photograph at left shows the Presserfoot Lock principle and the proper placement of the Locking Cam (#2 at left). When the Backplate is in place, the Locking Cam should sit on a slight angle to the Presserfoot Rod (#1 at left) as shown. Shims are placed between the Backplate and Housing to adjust for wear (#3 at left). Add or remove shims as needed to get proper angle on locking cam (#2) as illustrated. If the rod slips, shims should be removed.

To assemble, first assemble the Presserfoot Lock Release, Spring and Pin (#4, #5 and #6 in photo at left). Then insert the Presserfoot Rod (#1 at left).

Insert a screw driver (#7) over the Presserfoot Rod (#1) and under the Presserfoot Lock Release (#4) to hold the Presserfoot Lock in the release position when replacing the Backplate. This must be done to prevent damage to the Backplate and to properly tighten Backplate screws. It will not go together without the lock being released. Be sure that shims (#3) are in place before final reassembly of the Backplate. Replace Locking Cam (#2).

BEFORE REPLACING THE BACKPLATE, be sure the sharpener has been moved down (1/2" - 13mm) to prevent damage to sharpener tripping mechanism.

Use a screw driver to turn and hold Locking Lever outward against spring tension. Then slip Locking Cam in position with pawl inserted in small arms of Locking Lever.

Keep screw driver in this holding position while putting backplate in position. Then fasten the 4 backplate screws.

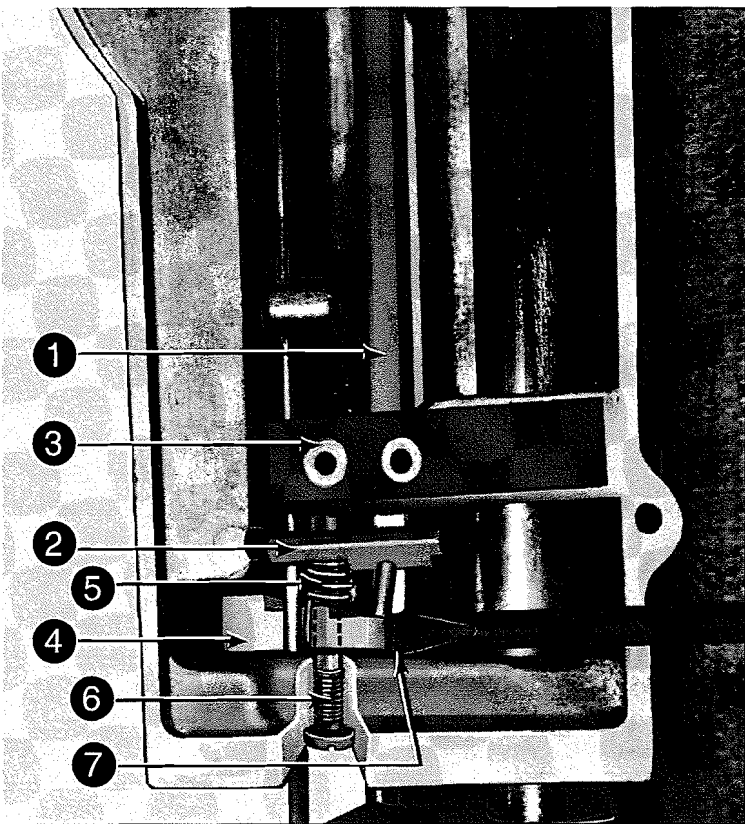

MAINTENANCE BELT SHARPENER SERIES ONLY

PAGES 12, 13 & 14

WHEN SHARPENING A NEW PACER

To engage Sharpener, press starting lever down as shown in the picture on page 7, FIG. C, #2. Allow Sharpener to run 5 or 6 strokes

for the best edge. The machine is then ready for cutting. **Do not over sharpen.**

CHANGING THE EMERY BELTS

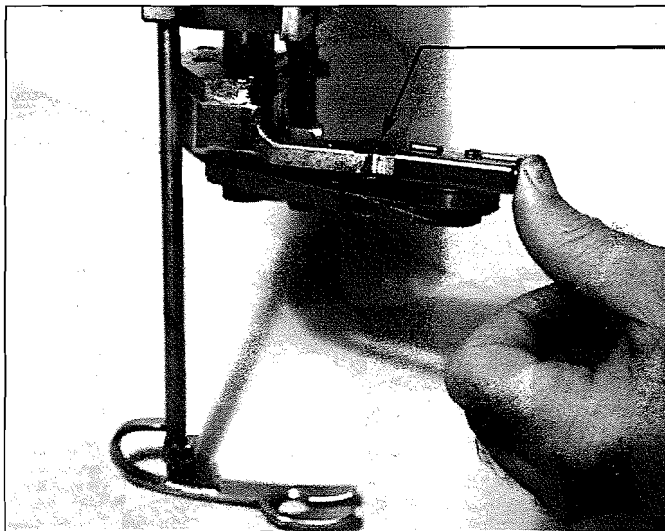

Oil Belt Pulleys here, 1 or 2 drops a week. **Do not over oil.**

To replace the Emery Belt, simply push the Carrier until Belt is released. Slip the new Belt on and release. The spring loaded quick-change mechanism will automatically provide the correct tension. Always change belts with the sharpener in the up position.

EMERY BELT APPLICATIONS

Wolf offers four different grades of emery belts to satisfy your cutting needs. With the selection from fine to very coarse. You can

sharpen your knives to cut every kind of fabric quickly and cleanly. The table below shows four belts types and the use for each.

BELT TYPE	WOLF No.	BEST SUITED FOR:
FINE (180 Grit)	1350000	Synthetics, Knits, Loosely woven materials.
MEDIUM (120 Grit)	1350100	Cottons, light Woolens.
COARSE (80 Grit)	1350200	Light Demins, tightly woven materials.
VERY COARSE (60 Grit)	1350300	Heavy Demin, Canvas, Leather.

PROPER ADJUSTMENT OF SHARPENER INSTRUCTIONS FOR NEW NON-ADJUSTABLE PRESSURE ARM

PACER XI Models have a new Non-adjustable Belt Pressure Arm which eliminates adjusting tension of the Emery Belt Pressure Arm. In addition to replacing the old Pressure Arm (#1323060) the following parts are also eliminated:

- 1331000 - 1331500 - Rod
- 1331700 - 1331800 - Silencer
- 1334000 - Release Rod Screw
- 1335000 - Spring
- 9901729 - Stop Nut
- 9902003 - Roll Pin

It is important that the Bevel Adjusting Shoulder Bushing (#1328100) notch be to the inside, outside or back depending on the bevel required.

The small wedge shaped block on the Non-adjustable Arm should be checked when in the sharpening position (near middle of Blade). It should be .005" (.127mm) .010" (.254mm) from the Blade or about the thickness of a piece of writing paper.

ADJUSTING BLADE BEVEL

To select a bevel that is best suited to the material to be cut, a general rule is to use the long bevel on medium and hard coarse fabrics and a progressively shorter bevel on finer materials.

TO ADJUST FOLLOW THESE STEPS:

1. Loosen Nut #1212200 and loosen Shoulder Screw (#1 below).
2. Use wrench to select bevel setting of cam and hold in position while tightening screw.
3. Hold Screw and tighten Nut.

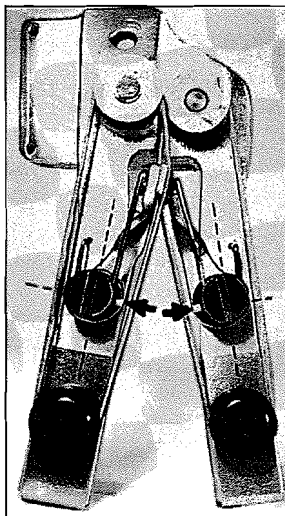

LONG BEVEL
1/16"
1.588mm

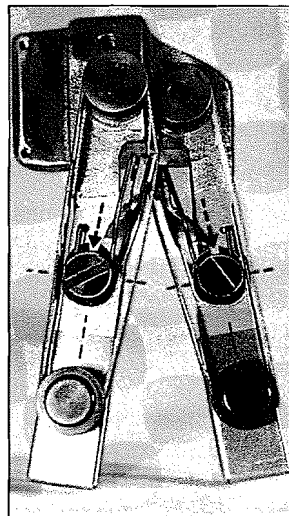

MEDIUM BEVEL
3/64"
1.191mm

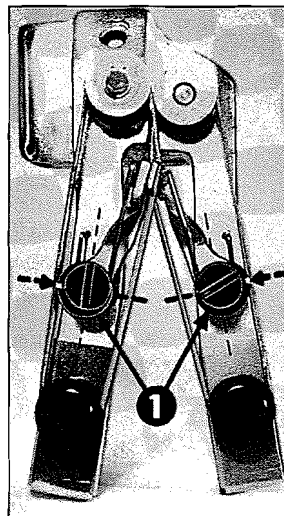

SHORT BEVEL
1/32"
.792mm

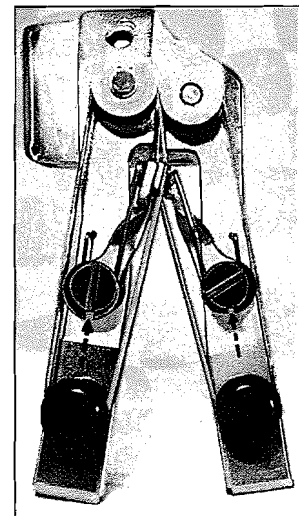

WAVE BLADE SETTING

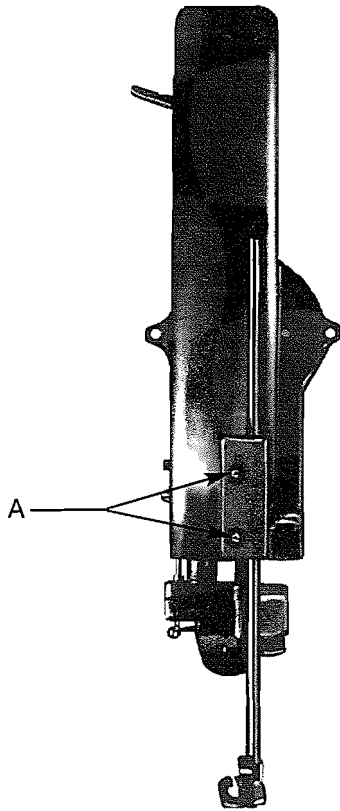

ADJUSTMENT OF PRESSERFOOT LOCK ASSEMBLY

NOTE:

The Presserfoot Lock Assembly needs to be adjusted only if the Presserfoot Rod is not holding.

The Presserfoot mechanism is positioned on the Front Housing and is disassembled by removing 2 screws (A at left). To reassemble, release the spring tension by depressing the Locking Lever with a screw driver as shown on page 11. Follow the instructions from paragraph 3 also on page 11.

HOW TO DISASSEMBLE SERIES XI SHARPENER

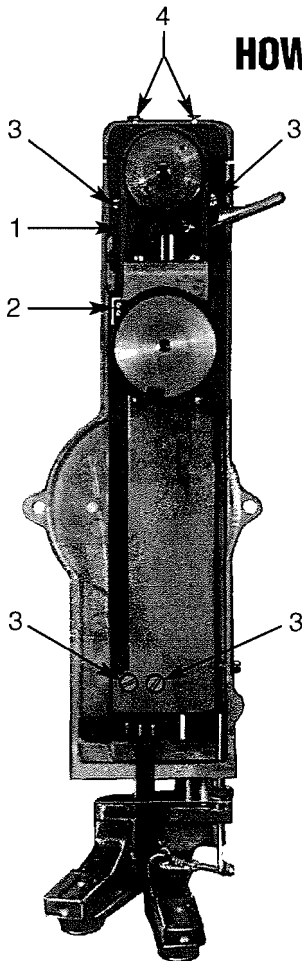

1. Remove top belt.
2. Remove three screws from nylon guide.
3. Remove four Backplate screws.
4. Remove two screws and cap of Front Housing.
5. Remove two screws and Cover Plate.
6. Remove Follower screw, Spring and Follower. Loosen Clamp screw. See Follower information on page 7 (at the bottom).
7. Remove the two Pins from Arm Release Rod.
8. Remove nut from bottom of Release Rod. Rod can then be removed.
9. Remove Locknut, Worm wheel and Key at top of Sharpener.
10. By sliding shaft down, the complete Reversing Drive Assembly can then be removed complete with Sharpening Head.

(NOTE: On new models disregard #'s 7 & 8.)

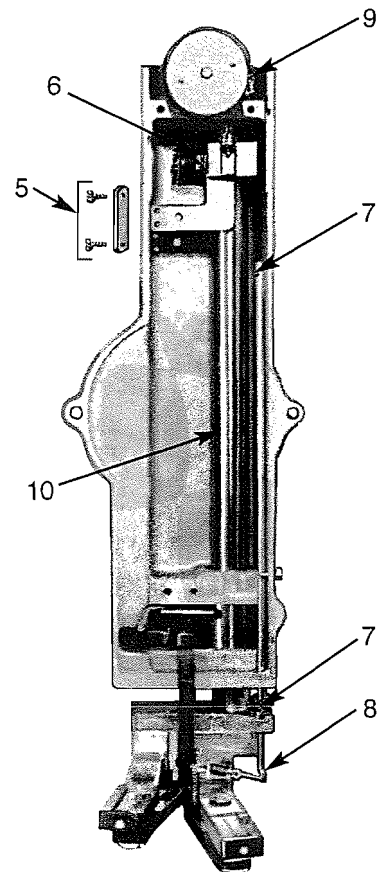

SECTION II – PACER PARTS ILLUSTRATIONS

This Parts Manual has been divided into the major assemblies shown below. Individual parts and their numbers to these assemblies can be found by turning to the pages indicated near each assembly.

Series VI & VII Stone Sharpener,
See pages 26 & 27.

Series VIII & XI Belt Sharpener,
See pages 28 & 29.

Series X Stone Sharpener,
See pages 26, 27 & #23.

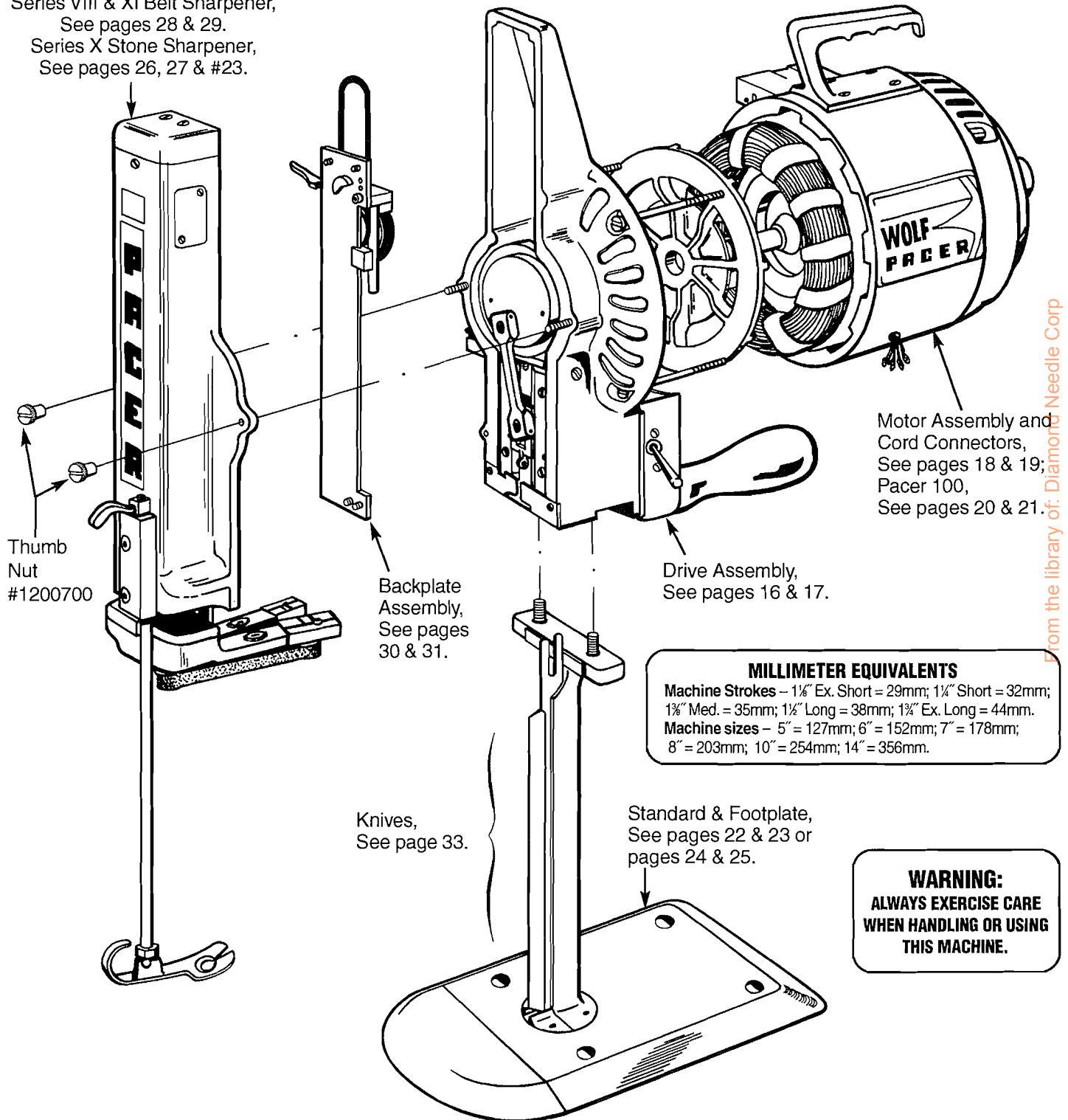

MILLIMETER EQUIVALENTS

Machine Strokes – 1 $\frac{1}{8}$ " Ex. Short = 29mm; 1 $\frac{1}{4}$ " Short = 32mm;
1 $\frac{1}{2}$ " Med. = 35mm; 1 $\frac{3}{4}$ " Long = 38mm; 1 $\frac{7}{8}$ " Ex. Long = 44mm.

Machine sizes – 5" = 127mm; 6" = 152mm; 7" = 178mm;
8" = 203mm; 10" = 254mm; 14" = 356mm.

WARNING:
ALWAYS EXERCISE CARE
WHEN HANDLING OR USING
THIS MACHINE.

NOTE: WHEN ORDERING PARTS – SPECIFY PART NUMBER, DESCRIPTION, MACHINE SIZE, MACHINE SERIAL NUMBER AND PARTS MANUAL EDITION.

From the library of: Diamond Needle Corp

DRIVE ASSEMBLY

- *1031959 (Heavy Duty Guides)
- *1032059 (Heavy Duty Guides)

- 1382153
- 1382179 (Graphite Guides)
- 1382178 (Graphite Guides)
- 1382175 (Graphite Guides)

- *1032400 (Heavy Duty Guides)

- *1032500 (Heavy Duty Guides)
Inserts through front head, in place of 9901716

- *1032650 (Heavy Duty Guides)
1382152 (Graphite Guides)

- 1202600 (14" after 1/89)

- 1202800 (10"-14")
- 9900818 (10"-14")

- 1202400 (10" after 1/89)

- 1020000 (5" - 8")
- 1020200 (10" before 1/89)
- 1021100 (14" before 1/89)

- 1020300 (10"-14" after 1/89)

- Pacer 100
- 1372300 (Super, 2 Speed & Jeans Mach.)
- 1372400 (Junior)
- Old Style
- 3003100 (Junior)
- 3003600 (Super, 2 Speed & Jeans Mach.)

- 1050200 (1-1/4" Stroke)
- 1050000 (1-3/8" Stroke)
- 1050100 (1-1/2" Stroke)
- 1050600 (1-3/4" Stroke)

- 1050400
- 1053000
- 1059093

- 1050300

- 1057093

- 1371400

- 9901863

- 1052060 - 1-3/8", 1-1/2", 1-3/4"
- 1052160 - 1-1/4"

- *1061060 (Heavy Duty Guides)
- 1384370 (Graphite Guides)

- 9900824

- 9901984

- 1030000

- 9901932
- 9900119

- 1032900

- 1384300

- 1063293

- 1020400

- 9900341

- 1031100

- 1051000

- 1051293

- 1029760

- 9900337

DEAD-MAN SWITCH

- 1026560
- 1026660

- 9900616

- 9900359

- 1026400

- 1027350

- 9901951

- 9901671

- 1028093
- 1028193

- 1026100

- 1069010

- 6048600

- 9900040

- 6047660

- 6048500

- 1026700

- 1027200

- 6045100

- 1026200

- 9900624

- 1026100

- 9901718

- 1026100

SEE KNIVES ON PAGE 33

- 9900824

- 9901984

- 1079000

- 1064050

- 1027093 (Reg.)
- 1027193 (2 Speed)
- 1026900 (42 Volt)

- 1080000

- 1076500

- 9900088

- 9900613

- 9900625

- 1026000

- 1386060

- 1027093 (Reg.)
- 1027193 (2 Speed)
- 1026900 (42 Volt)

- 1080000

- 1076500

- 9900088

- 9900613

- 9900625

- 1026000

- 1386060

NOT SHOWN

- Bushing (2 Speed) 1027600
- Washer (2 Speed) 1086400
- Switch Lever Stop (2 Speed) 1027500

NUMBERS FOR DRIVE ASSEMBLY

IN NUMERICAL ORDER

Part No.	Description	Quantity used if more than 1	Part No.	Description	Quantity used if more than 1
1020000	Front Head 5" - 8"		1063052	Crosshead Assembly Complete	
1020200	Front Head 10" (Pacers before 1/89)		1063293	Pin	
1020300	Front Head 10"-14" (Pacers after 1/89)		1064050	Knife Bolt and Washer	
1020400	Locking Pin		1069010	Handle - Dead-Man Switch	
1021100	Front Head 14" (Pacers before 1/89)		1076050	Presser Foot Lever	
1026000	Switch Box - Super		1076500	Lever Return Spring	
1026100	Switch Box		1076600	Pivot Pin	
1026200	Pivot Pin		1079000	Footlock Push Rod	
1026300	Heat Shield		1080000	Push Rod Bushing	
1026400	Trigger		1086400	Washer	
1026560	Dead-Man Switch Complete - Reg. & Jr.		1202400	Upper Cover 10" (Pacers after 1/89)	
1026660	Dead-Man Switch Complete - Dual		1202600	Upper Cover 14" (Pacers after 1/89)	
1026700	Adapter Plate		1202800	Joint Tab 10"-14" (Pacers after 1/89)	2
1026900	Switch - 42 Volt		1371400	Snap Ring	
1027093	Switch - Super		1372300	Motor Bolt (Pacer 100)	
1027193	Switch - 2 Speed			Super, 2 Speed & Jeans Machine	4
1027200	Switch Mounting Bracket		1372400	Motor Bolt (Pacer 100) - Jr.	4
1027350	Switch Assembly Complete		1382152	Distributor Tube Assy. for Regular Guides	
1027500	Switch Lever Stop - 2 Speed (not shown)		1382153	Lubricator S.A.	
1027600	Bushing - 2 Speed (not shown)		1382175	Oiler Mounting Tube	
1028093	Over ride Switch - Reg. & Jr.		1382178	Lubricator Mounting Bracket	
1028193	Over ride Switch - Dual only		1382179	Oil Hole Cover - Regular Guides	
1029760	Drip Pan		1384300	Oil Pad	
1030000	Oil Shield		1384370	Fixed Guide (Graphite)	
1031100	Drip Pad Felt		1386060	Handle with Stud	
*1031959	Oiler Complete (Heavy Duty Guides)		3003100	Motor Bolt (Old style) - Jr.	4
*1032059	Oiler Body S.A. (Heavy Duty Guides)		3003600	Motor Bolt (Old style) - Super, 2 Speed & Jeans Machine	4
*1032400	Mounting Collar (Heavy Duty Guides)			Thin Nut	
*1032500	Mounting Tube (Heavy Duty Guides)		6045100	Thin Nut	
*1032650	Distributor Tube Assy. (Heavy Duty Guides)		6047660	Switch Bracket and Spring	
1032893	Pipe Cleaner		6048500	Insulator	2
1032900	Distributor Wick		6048600	Switch	2
1050000	Crank 1-3/8"		9900040	Screw	2
1050100	Crank 1-1/2"		9900088	Switch Screw	2
1050200	Crank 1-1/4"		9900119	Screw for Oiler Shield	
1050300	Crank Wrist Pin		9900165	Lubricator Tube Screw	
1050400	Wrist Pin Screw		9900337	Drip Pan Screw	4
1050600	Crank 1-3/4"		9900341	Screw for Drip Pad	
1051000	Crosshead Wrist Pin		9900357	Flat Head Screw for 1056100	3
1051193	Retaining Ring		9900359	Screw for 1027200	2
1051293	Wavy Washer		9900613	Switch Box Screw	2
1051300	Fibre Washer		9900616	Switch Box Screw 7/8" (22.22mm)	2
1052060	Connecting Rod with screws 1-1/8", 1-1/2" 1-3/4" Strokes		9900624	Switch Box Screw 2-1/2" (63.49mm)	2
1052160	Connecting Rod with screws 1-1/4" Strokes		9900625	Switch Box Screw	2
1053000	Bearing Locknut		9900818	Pan Head Screw 10"-14" (Pacers after 1/89)	4
1056100	Bearing Retainer (not shown)		9900824	Screw for Guides	4
1057093	Front Head Bearing		9901671	Nut	2
1059093	Crank Bearing		9901716	Half Nut 1/4"-28	
*1061060	Heavy Duty Guide S.A.	2	9901718	Half Nut 3/8"-24	
1062200	Locknut	2	9901797	Set Screw	2
1062300	Set Screw	2	9901863	Stud	2
1063000	Crosshead		9901932	Lock Washer	
			9901951	Lock Washer	4
			9901984	Washer	

From the library of: Diamond Needle Corp

HEAVY DUTY GUIDE CHANGEOVER KIT

* **HEAVY DUTY GUIDES** - Wolf offers heavy duty guides to those who would like them. These guides, unlike the graphite guides, do require lubrication and consequently a different lubricator and distributor tube. Below are the part numbers for parts necessary for changing to these heavy duty guides:

#1390150 Heavy Duty Guide Kit Complete

#1031959 Guide Oiler Complete #1061060 Heavy Duty Guide S.A.
#1032650 Distributor Tube S.A. #1386400 Guide Wick (2 Req'd)

MILLIMETER EQUIVALENTS | Machine Strokes: 1-1/8" Ex. Short = 29mm; 1-1/4" Short = 32mm; 1-3/8" Med. = 35mm; 1-1/2" Long = 38mm; 1-3/4" Ex. Long = 44mm.
Machine Sizes: 5" - 127mm; 6" - 152mm; 7" - 178mm; 8" - 203mm; 10" - 254mm; 14" - 356mm.

MOTOR AND CONNECTOR BOX ASSEMBLIES

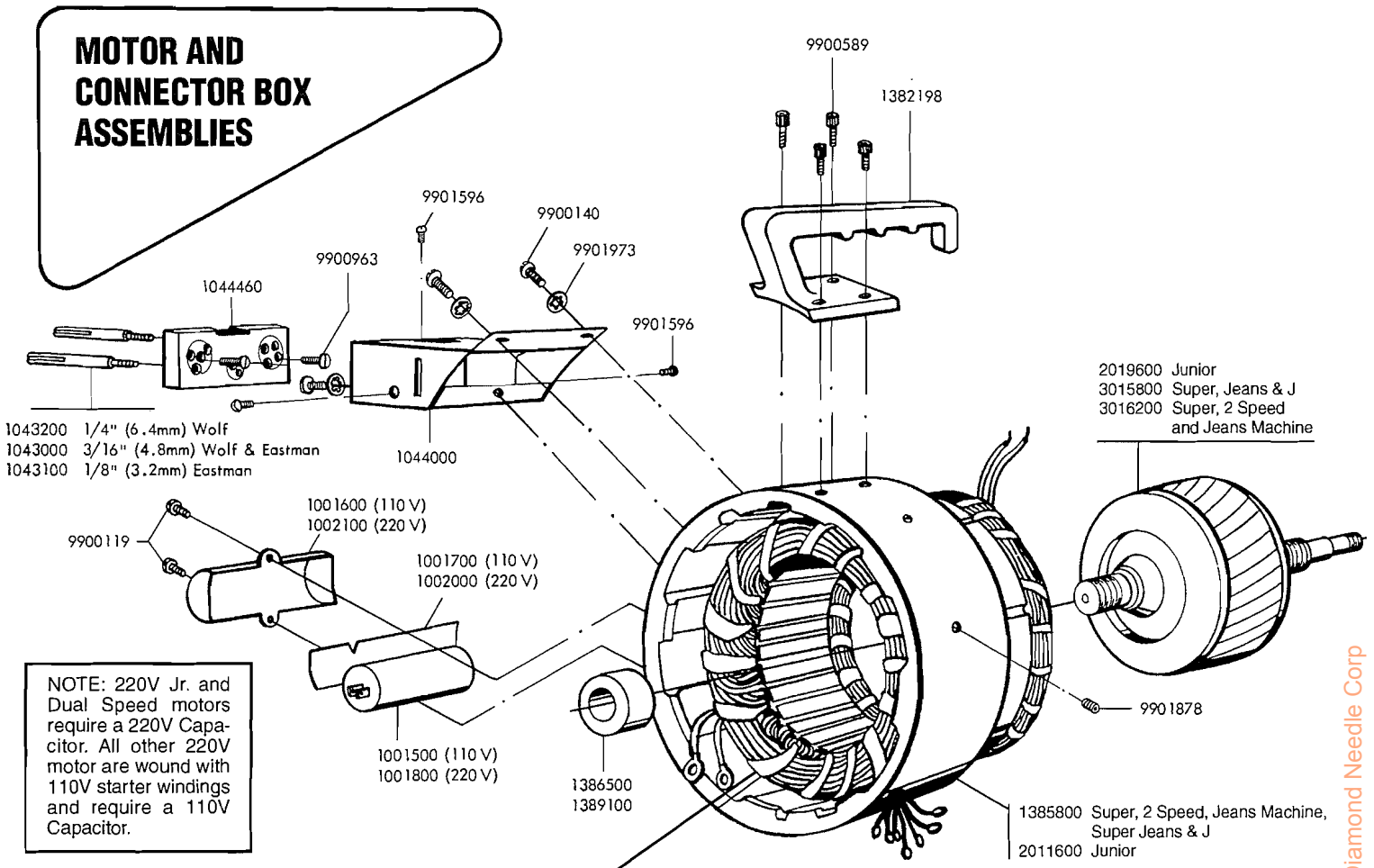

Description	Part No.	Voltage
STATOR for Super and Jeans Machine	3011001	110/1/60
	3011002	110/1/50
	3011003	100/1/60
	3011004	220/1/50
	3011005	220/1/60
	3011016	220/3/60
	3011017	440/3/60
	3011022	440/3/50
	3011026	380/3/50
	3011035	220/3/50
3011038	100/1/50	
STATOR for 2 Speed	1011201	110/1/60
	1011202	110/1/50
	1011203	100/1/60
	1011204	220/1/50
	1011205	220/1/60
	1011216	220/3/60
	1011217	440/3/60
	1011222	440/3/50
	1011226	380/3/50
	1011235	380/3/50
	1011238	100/1/50
	STATOR for Jr.	2011101
2011102		110/1/50
2011103		100/1/60
2011104		220/1/50
2011105		220/1/50
2011116		220/3/60
2011117		440/3/60
2011122		440/3/50
2011126		380/3/50
2011135		220/3/50
2011138	110/1/50	
STATOR Super Series J	3011111	220-380/3/50-60
FOR ANY OTHER VOLTAGE PLEASE SPECIFY		

Part No.	Description	Quantity used if more than 1
1001500	110V Capacitor - Super & Jeans Machine, all voltages, 1 phase; Jr. & Dual, 110V, 1 phase	
1001600	110V Capacitor Cover	
1001700	110V Capacitor Insulator	
1001800	220V Capacitor - Jr., Dual, 220V only, 1 phase	
1002000	220V Capacitor Insulator	
1002100	220V Capacitor Cover	
1043000	3/16" (4.8mm) Connection Post-Wolf 3 Ph. & Eastman	3
1043100	1/8" (3.2mm) Connection Post - Eastman	as required
1043200	1/4" (6.4mm) Connection Post - Wold 1 phase	2
1043500	Ground Strap (not shown)	
1043900	Ground Center Post 1/4" - Wolf only (not shown)	
1044000	Connection Box	
1044600	Connection Block Assembly	
1382198	Top Handle	
1385800	Motor Case - Super, 2 Speed, Jeans Machine, Super Jeans and J	
1386300	Front Fan (not shown)	
1386500	Front Fan Spacer (not shown)	
1389100	Front Spacer	
2011600	Motor Case - Jr.	
2019600	Rotor - Jr.	
3015800	Rotor - Super Jeans, Super Series J	
3016200	Rotor - Super, 2 Speed & Jeans Machine	
9900119	Screw for Capacitor Cover	2
9900140	Screw for Connector Box	3
9900337	Terminal Board Mounting Plate Screw - Jr. (3 Phase) (not shown)	
9900589	Screw for Top Handle	4
9900963	Connector Block Screw	2 or 3
9901596	Screw to secure Block	3
9901878	1/4"-20 x 1/4 Socket Head Set Screw	2
9901973	Washer	3

From the library of: Diamond Needle Corp

Installation - Twist-Lock Type Electrical Connector

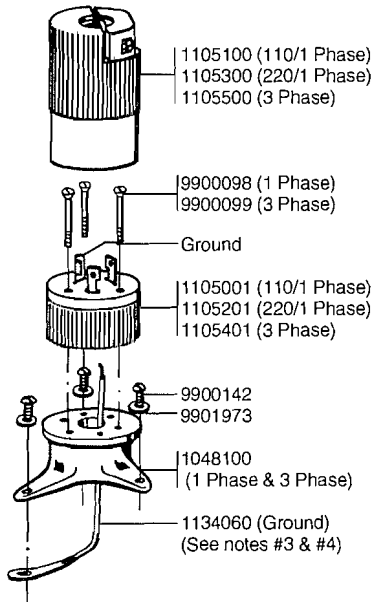

1. Disconnect electrical connector.
2. Remove old type connection box. Pull out terminal block by removing the 3 screws on the outside of connection box. Disconnect wires on the back of the block.
3. If the new male plug is mounted on the Twist-Lock base, remove it. Bring lead wires through new base being installed. Before base is secured to motor case, the Green Ground wire #1 134060 must be properly attached. Note: Place ground between base and motor case, attaching it with any one of the screws, leading the other end up through the base.
4. Connect leads and ground wires to male plug. Make certain ground wire is connected to right angle shaped terminal pin. Note: Be sure three phase machines rotate in same direction as arrow stamped on the rear motor case. To check, make a flash contact with switch turned on. If rotation is incorrect, reverse by changing the lead wires on the male plug. Motor must rotate in proper direction or serve damage will result.

Cord Connector

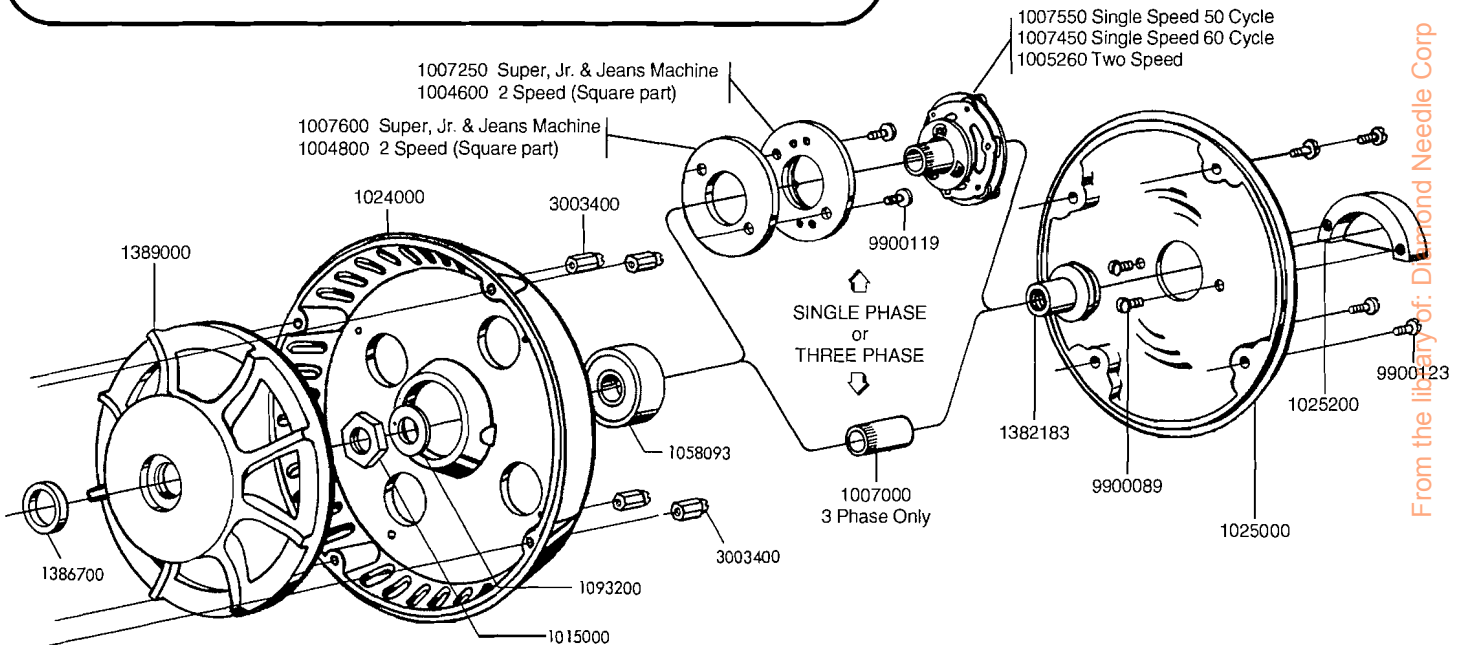
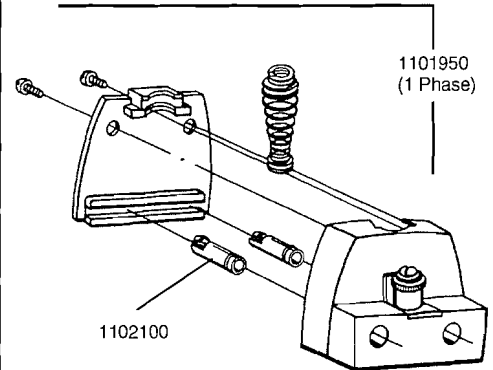

MOTOR AND CORD CONNECTOR NUMBERS - IN NUMERICAL ORDER

Part No.	Description	Quantity used if more than 1	Part No.	Description	Quantity used if more than 1
1004600	Inner Breaker - 2 Speed - 1 Phase (Square part)		1105001	110/1 Phase Twist-Lock Male Plug	
1004800	Insulator - 2 Speed - 1 Phase (Square part)		1105100	110/1 Phase Twist-Lock Male Plug	
1005260	Outer Breaker - 2 Speed - 1 Phase		1105201	220/1 Phase Twist-Lock Female Plug	
1007000	3 Phase Spacer		1105300	220/1 Phase Twist-Lock Female Plug	
1007250	Inner Breaker - Super, Jr. & Jeans Machine - 1 Phase		1105401	3 Phase Hubbell Male Plug	
1007450	Outer Breaker 60 Cycle - Single Speed - 1 Phase		1105500	3 Phase Hubbell Female Plug	
1007550	Outer Breaker 50 Cycle - Single Speed - 1 Phase		1134060	Ground Wire	
1007600	Insulator - Super, Jr. & Jeans Machine - 1 Phase		1382183	Rotor Knob S.A.	
1014000	Fan		1386700	Spacer	
1015000	Fan Locknut		3003400	Acorn Nut (8 on Dual & Jeans Machine)	4
1024000	Rear Head		9900089	Knob Cover Screw	2
1025000	Rear Cover		9900098	Screw for 1 Phase Plug	3
1025200	Knob Cover		9900099	Screw for 3 Phase Plug	2
1048100	Twist-Lock Connector Base - 1 Phase & 3 Phase		9900119	Screw for Breaker	2
1058093	Rear Head Bearing		9900123	Screw for Rear Cover	4
1093200	Bearing Spacer		9900142	Screw for Hubbell Base	3
1101950	1 Phase Connection		9901973	Washer	3
1102100	1 Phase Brass Insert				

PACER 100 MOTOR AND CONNECTOR BOX ASSEMBLIES

For Super Pacer 100, 2 Speed 100, Jeans Machine 100 and Jr. 100

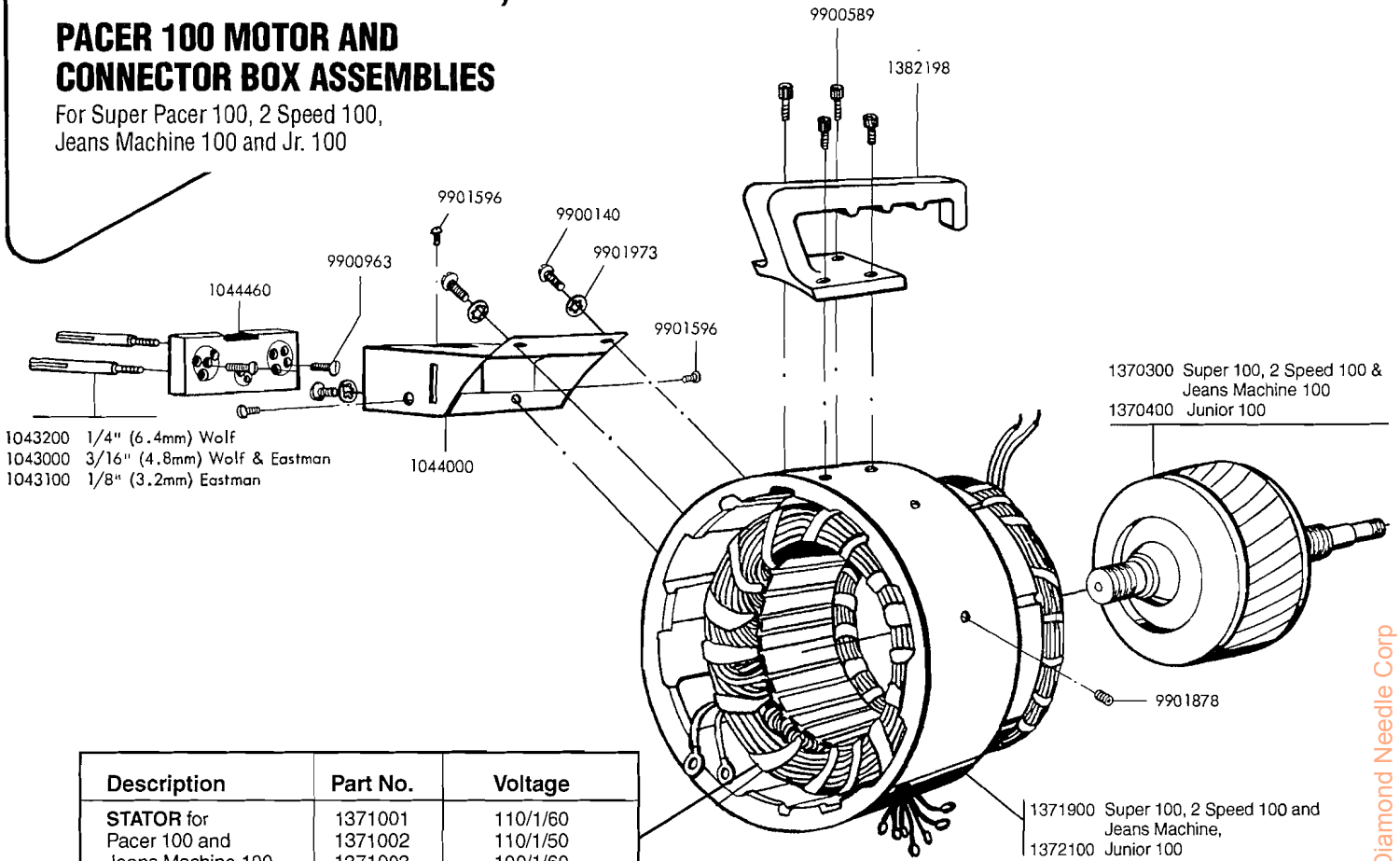

Description	Part No.	Voltage
STATOR for Pacer 100 and Jeans Machine 100	1371001	110/1/60
	1371002	110/1/50
	1371003	100/1/60
	1371004	220/1/50
	1371005	220/1/60
	1371016	220/3/60
	1371017	440/3/60
	1371022	440/3/50
	1371026	380/3/50
	1371035	220/3/50
1371038	100/1/50	
STATOR for 2 Speed 100	1371201	110/1/60
	1371202	110/1/50
	1371203	100/1/60
	1371204	220/1/50
	1371205	220/1/60
	1371216	220/3/60
	1371217	440/3/60
	1371222	440/3/50
	1371226	380/3/50
	1371235	220/3/50
1371238	100/1/50	
STATOR for Jr. 100	1371101	110/1/60
	1371102	110/1/50
	1371103	100/1/60
	1371104	220/1/50
	1371105	220/1/60
	1371116	220/3/60
	1371117	440/3/60
	1371122	440/3/50
	1371126	380/3/50
	1371135	220/3/50
1371138	110/1/50	
FOR ANY OTHER VOLTAGE PLEASE SPECIFY		

Part No.	Description	Quantity used if more than 1
1043000	3/16" (4.8mm) Connection Post-Wolf 3 Ph. & Eastman	3
1043100	1/8" (3.2mm) Connection Post - Eastman	as required
1043200	1/4" (6.4mm) Connection Post - Wolf 1 phase	2
1043500	Ground Strap (not shown)	
1043900	Ground Center Post 1/4" - Wolf only (not shown)	
1044000	Connection Box	
1044460	Connection Block Assembly	
1370300	Rotor - Super, 2 Speed & Jeans Machine	
1370400	Rotor - Jr.	
1371900	Motor Case - Super, 2 Speed & Jeans Machine	
1372100	Motor Case - Jr.	
1382198	Top Handle	
9900140	Screw for Connector Box	3
9900589	Screw for Top Handle	4
9900963	Connector Block Screw	2 or 3
9901596	Screw to secure Block	3
9901878	1/4"-20 x 1/4 Socket Head Set Screw	2
9901973	Washer	

Installation - Twist-Lock Type Electrical Connector

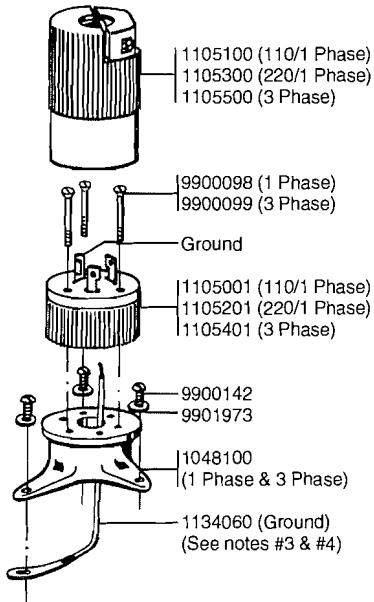

1. Disconnect electrical connector.
2. Remove old type connection box. Pull out terminal block by removing the 3 screws on the outside of connection box. Disconnect wires on the back of the block.
3. If the new male plug is mounted on the Twist-Lock base, remove it. Bring lead wires through new base being installed. Before base is secured to motor case, the Green Ground wire #1134060 must be properly attached. Note: Place ground between base and motor case, attaching it with any one of the screws, leading the other end up through the base.
4. Connect leads and ground wires to male plug. Make certain ground wire is connected to right angle shaped terminal pin. Note: Be sure three phase machines rotate in same direction as arrow stamped on the rear motor case. To check, make a flash contact with switch turned on. If rotation is incorrect, reverse by changing the lead wires on the male plug. Motor must rotate in proper direction or serve damage will result.

Cord Connector

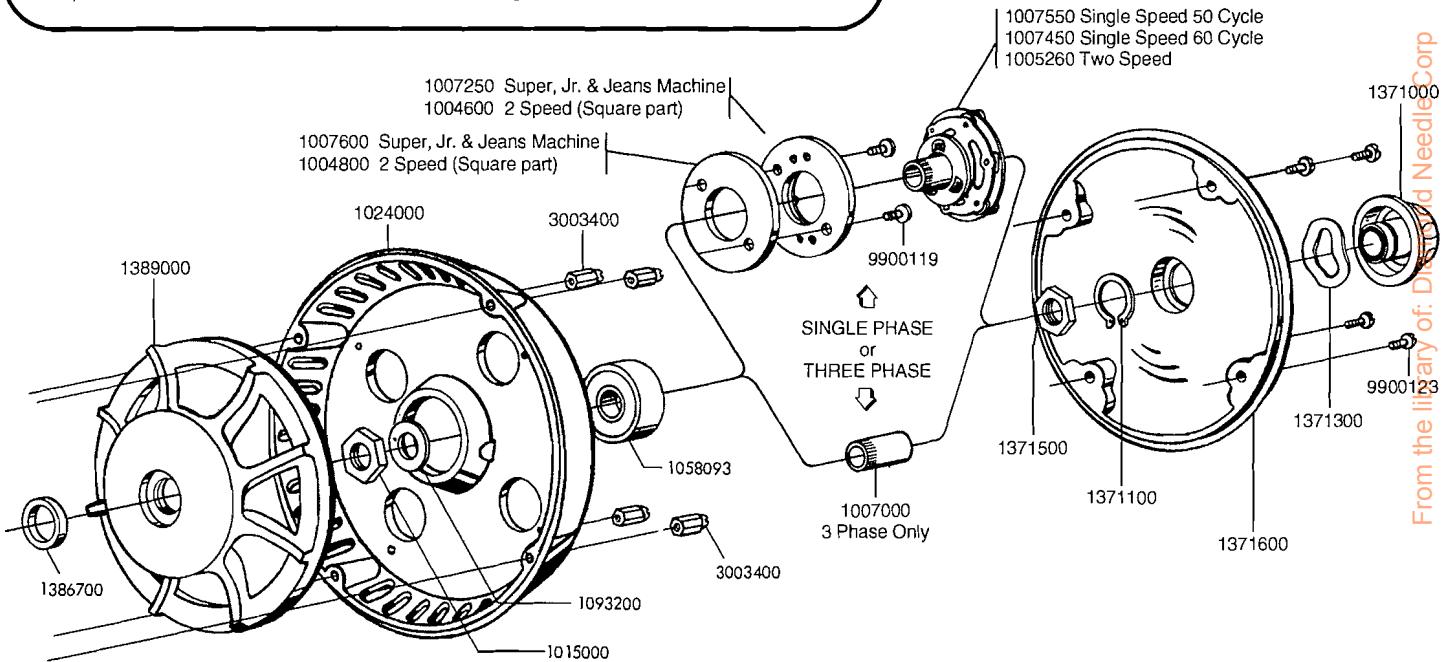
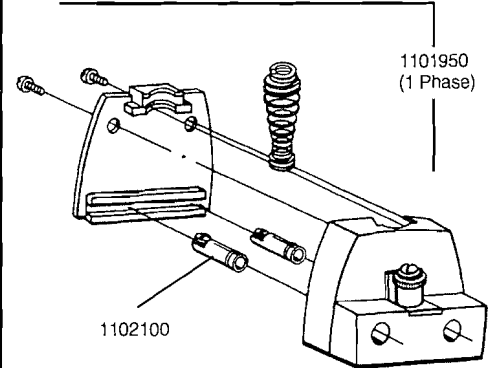

MOTOR AND CORD CONNECTOR NUMBERS - IN NUMERICAL ORDER

Part No.	Description	Quantity used if more than 1	Part No.	Description	Quantity used if more than 1
1004600	Inner Breaker, 2 Speed - 1 Phase (Square part)		1105201	220/1 Phase Twist-Lock Male Plug	
1004800	Insulator - 2 Speed - 1 Phase (Square part)		1105300	220/1 Phase Twist-Lock Female Plug	
1005260	Outer Breaker - 2 Speed - 1 Phase		1105401	3 Phase Hubbell Male Plug	
1007000	3 Phase Spacer		1105500	3 Phase Hubbell Female Plug	
1007250	Inner Breaker - Super, Jr. & Jeans Machine - 1 Phase		1134060	Ground Wire	
1007450	Outer Breaker 60 Cycle - Single Speed - 1 Phase		1371000	Knob	
1007550	Outer Breaker 50 Cycle - Single Speed - 1 Phase		1371100	Clip	
1007600	Insulator - Super, Jr. & Jeans Machine - 1 Phase		1371300	Spring	
1015000	Fan Locknut		1371600	Rear Cover	
1024000	Rear Head		1389000	Fan	
1048100	Twist-Lock Connector Base - 1 Phase & 3 Phase		3003400	Acorn Nut (8 on Dual & Jeans Machine)	4
1058093	Rear Head Bearing		9900098	Screw for 1 Phase Plug	3
1093200	Bearing Spacer		9900099	Screw for 3 Phase Plug	2
1101950	1 Phase Connection		9900119	Screw for Breaker	2
1102100	1 Phase Brass Insert		9900123	Screw for Rear Cover	4
1105001	110/1 Phase Twist-Lock Male Plug		9900142	Screw for Hubbell Base	3
1105100	110/1 Phase Twist-Lock Female Plug		9901973	Washer	3

NEW STYLE STANDARD, FOOTPLATE AND LIFTER ASSEMBLIES

STANDARD COMPLETE WITH INSERT & SCREWS
See numbers on page 23.

REG. INSERTS

- 1066000 5"
- 1066100 6"
- 1066200 7"
- 1066300 8"
- 1066400 10"
- 1067300 14"

KLEEN-KUT INSERTS

- 1067500 5"
- 1067600 6"
- 1067700 7"
- 1067800 8"
- 1067900 10"
- 1067400 14"

SEE KNIVES
ON PAGE 33

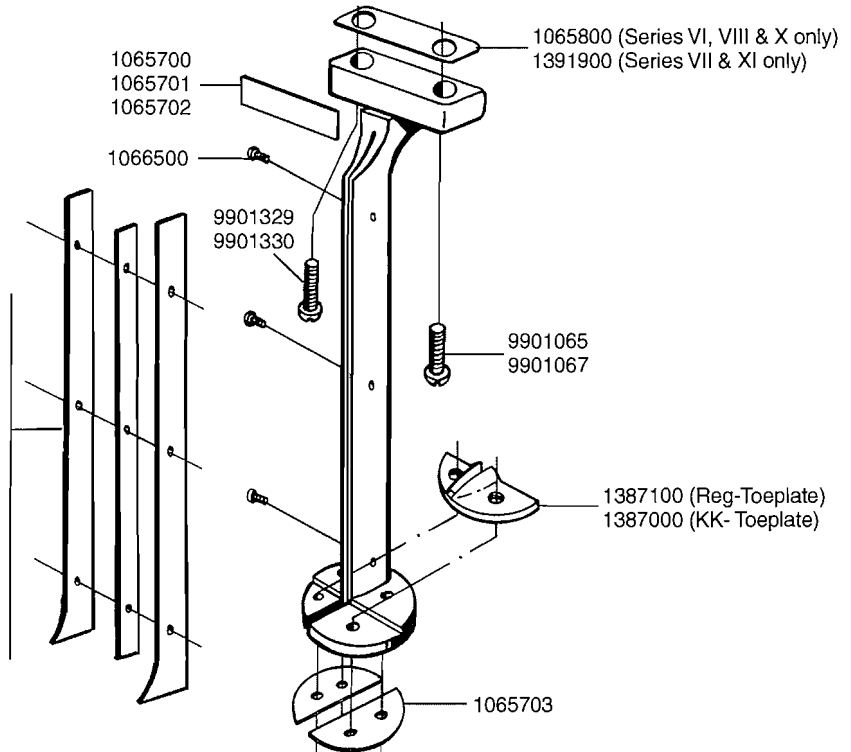

1387600 FOOTPLATE COMPLETE

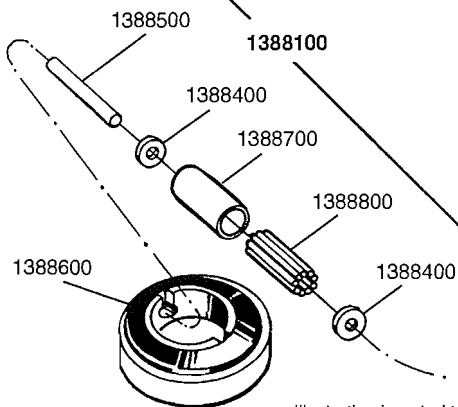
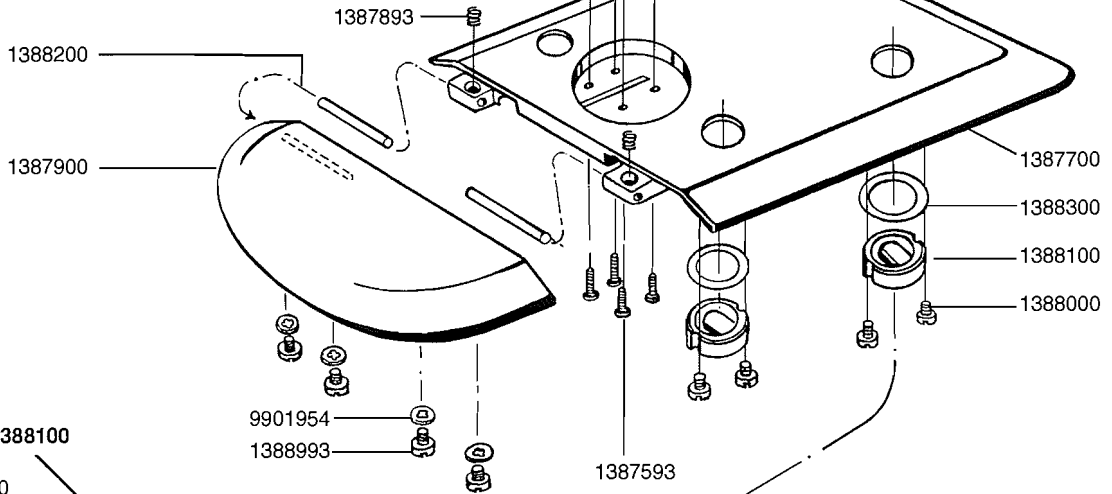

Illustration inverted to show assembly.

MILLIMETER EQUIVALENTS

Machine Strokes – 1-1/8" Ex. Short = 29mm;
1-1/4" Short = 32mm; 1-3/8" Med. = 35mm;
1-1/2" Long = 38mm; 1-3/4" Ex. Long = 44mm.
Machine sizes – 5" = 127mm; 6" = 152mm;
7" = 178mm; 8" = 203mm; 10" = 254mm;
14" = 356mm.

NUMBERS FOR FOOTPLATE, LIFTER AND STANDARD ASSEMBLIES

IN NUMERICAL ORDER

Part No.	Description	Quantity used if more than 1	Part No.	Description	Quantity used if more than 1
Standard Complete with Inserts - 1¼", 1" & ½" Stroke			Standard Complete with Inserts - 1¼" Stroke		
1065050	5" Standard with Kleen-Kut Inserts		1066400	Set of Regular Inserts 10"	
1065051	5" Standard with Regular Inserts		1066500	Insert Screws	2 or 3
1065150	6" Standard with Kleen-Kut Inserts		1067050	Set Regular Toes (Left & Right)	
1065151	6" Standard with Regular Inserts		1067094	Regular Toe - Left	
1065250	7" Standard with Kleen-Kut Inserts		1067095	Regular Toe - Right	
1065251	7" Standard with Regular Inserts		1067150	Set of Kleen-Kut Toes (Left & Right)	
1065350	8" Standard with Kleen-Kut Inserts		1067294	Kleen-Kut Toe - Left	
1065351	8" Standard with Regular Inserts		1067295	Kleen-Kut Toe - Right	
1065450	10" Standard with Kleen-Kut Inserts		1067300	Set of Regular Inserts 14"	
1065451	10" Standard with Regular Inserts		1067400	Set of Kleen-Kut Inserts 14"	
1065550	14" Standard with Kleen-Kut Inserts		1067500	Set of Kleen-Kut Inserts 5"	
1065551	14" Standard with Regular Inserts		1067600	Set of Kleen-Kut Inserts 6"	
			1067700	Set of Kleen-Kut Inserts 7"	
			1067800	Set of Kleen-Kut Inserts 8"	
			1067900	Set of Kleen-Kut Inserts 10"	
			1387000	Kleen-Kut Toeplate	
1068550	6" Standard with Kleen-Kut Inserts		1387100	Regular Toeplate	
1068551	6" Standard with Regular Inserts		1387593	Hardened Screw	4
1068650	7" Standard with Kleen-Kut Inserts		1387600	Footplate Complete	
1068651	7" Standard with Regular Inserts		1387700	Footplate	
1068750	8" Standard with Kleen-Kut Inserts		1387893	Lifter Spring	2
1068751	8" Standard with Regular Inserts		1387900	Lifter	
1068850	10" Standard with Kleen-Kut Inserts		1388000	Screw - Roller Retainer	8
1068851	10" Standard with Regular Inserts		1388100	Roller Assembly	4
1068950	14" Standard with Kleen-Kut Inserts		1388200	Lifter Pin	2
1068951	14" Standard with Regular Inserts		1388300	Shim - Roller Assembly	As Req'd
1065700	Shim for Front Head/Standard .005" (.127mm)		1388400	Roller Washer	8
1065701	Shim for Front Head/Standard .010" (.254mm)		1388500	Roller Shaft	4
1065702	Shim for Front Head/Standard .020" (.508mm)		1388600	Roller Housing	4
1065703	Shim for Standard/Footplate	2	1388700	Roller Shell	4
1065800	Shim (1½" Stroke) (Series VI, VIII & XI only)		1388800	Roller Pins	40
1066000	Set of Regular Inserts 5"		1388993	Screw - REtainer Lifter	4
1066100	Set of Regular Inserts 6"		1391900	Spacer (10" Series VII & XI only)	
1066200	Set of Regular Inserts 7"		9901065	Screw for Standard (1¼", 1" & ½" Stroke)	
1066300	Set of Regular Inserts 8"		9901067	Screw for Standard (1¼" Stroke)	
			9901329	Screw for Standard (1¼", 1" & ½" Stroke)	
			9901954	Lock Washer	4

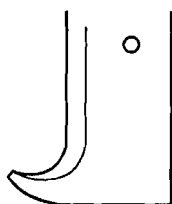

*Note: #1067150 Toes are required with Kleen-Kut Inserts

KLEEN-KUT INSERTS

Wolf pioneered Kleen-Kut inserts. They improve cutting through pile, knits, and all soft or loosely woven materials. As a result of their, clean shear cut, Kleen-Kut inserts help prevent unraveling and eliminates the packing or jamming of threads in the Footplate. All new Pacers, except the Jeans Machine™, have Kleen-Kut inserts installed at the factory since they are best for most types of cutting.

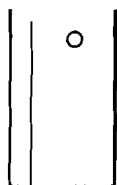

*Note: #1067050 Toes are required with Kleen-Kut Inserts

REGULAR INSERTS

Wolf's regular inserts are best for the cutting of demin and hard materials which do not unravel when cut. Regular inserts are more economical than Kleen-Kut inserts since they are reversible and cost less initially. Unless specifically ordered, regular inserts are not installed on new Pacers - except for the Jeans Machine™.

MILLIMETER EQUIVALENTS | Machine Strokes: 1-1/8" Ex. Short = 29mm; 1-1/4" Short = 32mm; 1-3/8" MEd. = 35mm; 1-1/2" Long = 38mm; 1-3/4" Ex. Long = 44mm.
Machine Sizes: 5" - 127mm; 6" - 152mm; 7" - 178mm; 8" - 203mm; 10" - 254mm; 14" - 356mm.

OLD STYLE STANDARD, FOOTPLATE AND LIFTER ASSEMBLIES

STANDARD COMPLETE WITH INSERT & SCREWS
See numbers on page 25

REG. INSERTS

- 1066000 5"
- 1066100 6"
- 1066200 7"
- 1066300 8"
- 1066400 10"
- 1067300 14"

KLEEN-KUT INSERTS

- 1067500 5"
- 1067600 6"
- 1067700 7"
- 1067800 8"
- 1067900 10"
- 1067400 14"

SEE KNIVES
ON PAGE 33

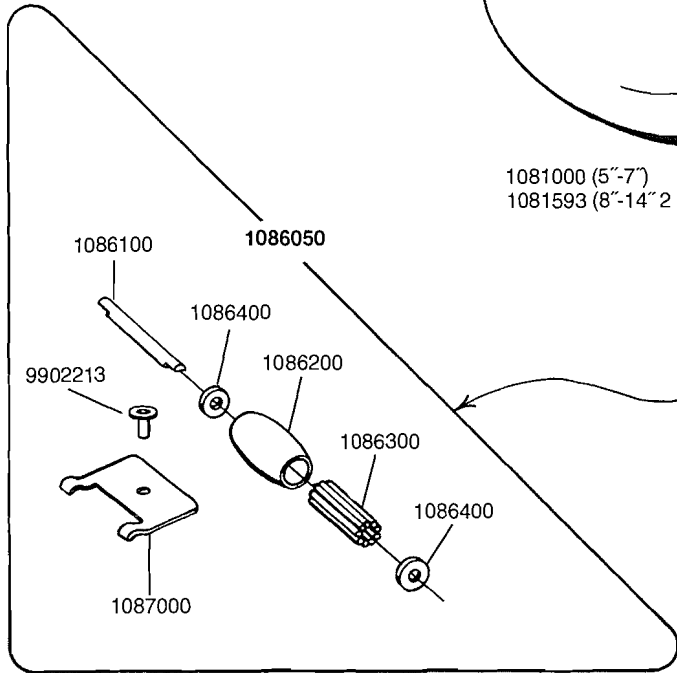

- 1081100 (5"-7")
- 9902029 (8"-14")

- 1082000 (5"-7")
- 1082400 (8"-14")

- 1084898 (8"-14")

- 1081000 (5"-7")
- 1081593 (8"-14" 2 req'd)

- 1085700

- 1085050 (5"-7")
- 1085151 (8"-14")
- (Complete w/Rollers)

- 9900161

- 1085200 (5"-7")
- (Retainer only)
- 1085800 (8"-14")
- (Retainer only)

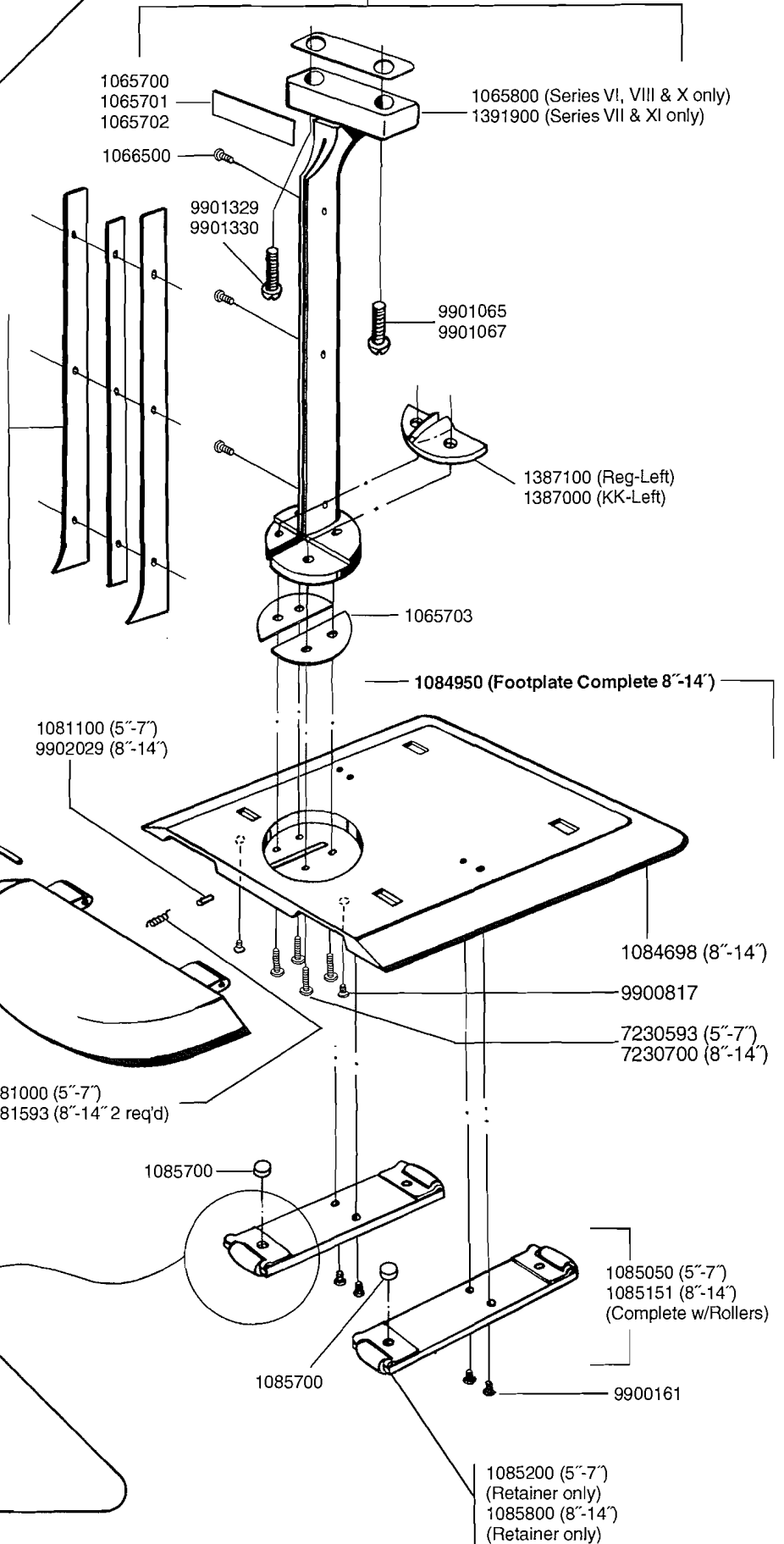

From the library of: Diamond Needle Corp

NUMBERS FOR FOOTPLATE, LIFTER AND STANDARD ASSEMBLIES

IN NUMERICAL ORDER

Part No.	Description	Quantity used if more than 1	Part No.	Description	Quantity used if more than 1
Standard Complete with Inserts - 1½" & 1½" Stroke			1067094	Regular Toe - Left	
1065050	5" Standard with Kleen-Kut Inserts		1067095	Regular Toe - Right	
1065051	5" Standard with Regular Inserts		1067294	Kleen-Kut Toe - Left	
1065150	6" Standard with Kleen-Kut Inserts		1067295	Kleen-Kut Toe - Right	
1065151	6" Standard with Regular Inserts		1067300	Set of Regular Inserts 14"	
1065250	7" Standard with Kleen-Kut Inserts		1067400	Set of Kleen-Kut Inserts 14"	
1065251	7" Standard with Regular Inserts		1067500	Set of Kleen-Kut Inserts 5"	
1065350	8" Standard with Kleen-Kut Inserts		1067600	Set of Kleen-Kut Inserts 6"	
1065351	8" Standard with Regular Inserts		1067700	Set of Kleen-Kut Inserts 7"	
1065450	10" Standard with Kleen-Kut Inserts		1067800	Set of Kleen-Kut Inserts 8"	
1065451	10" Standard with Regular Inserts		1067900	Set of Kleen-Kut Inserts 10"	
1065550	14" Standard with Kleen-Kut Inserts		1081000	Lifter Spring (5"-7")	
1065551	14" Standard with Regular Inserts		1081100	Lifter Pin (5"-8")	
Standard Complete with Inserts - 1¼" Stroke			1081593	Lifter Spring (8"-14")	2
1068550	6" Standard with Kleen-Kut Inserts		1082000	Hinge Pin (5"-7")	
1068551	6" Standard with Regular Inserts		1082400	Hinge Pin (8"-14")	
1068650	7" Standard with Kleen-Kut Inserts		1084698	Foot Plate (8"-14")	
1068651	7" Standard with Regular Inserts		1084898	Lifter (8"-14")	
1068750	8" Standard with Kleen-Kut Inserts		1084950	Foot Plate Complete (8"-14")	
1068751	8" Standard with Regular Inserts		1085050	Rollers & Retainer Assembly (5"-7")	2
1068850	10" Standard with Kleen-Kut Inserts		1085151	Rollers & Retainer Assembly (8"-14")	2
1068851	10" Standard with Regular Inserts		1085700	Retainer Cushions (5"-7" 2 req'd; 8"-14" 4 req'd)	
1068950	14" Standard with Kleen-Kut Inserts		1086050	Roller Sub-Assembly	4
1068951	14" Standard with Regular Inserts		1086100	Roller Shaft	4
1086200	Roller Shell		1086200	Roller Shell	4
1086300	Roller Pins	44	1086300	Roller Pins	44
1086400	Roller Washer	8	1086400	Roller Washer	8
1391900	Spacer (10" Series VII & XI only)		1391900	Spacer (10" Series VII & XI only)	
7230593	Hardened Screw (5"-7")	4	7230593	Hardened Screw (5"-7")	4
7230700	Hardened Screw (8"-14")	4	7230700	Hardened Screw (8"-14")	4
9900161	Screw for Retainer	4	9900161	Screw for Retainer	4
9900817	Screw for Lifter	2	9900817	Screw for Lifter	2
9901065	Screw for Standard (1½" & 1½" Stroke)		9901065	Screw for Standard (1½" & 1½" Stroke)	
9901067	Screw for Standard (1¼" Stroke)		9901067	Screw for Standard (1¼" Stroke)	
9901329	Screw for Standard (1½" & 1½" Stroke)		9901329	Screw for Standard (1½" & 1½" Stroke)	
9901330	Screw for Standard (1¼" Strokes)		9901330	Screw for Standard (1¼" Strokes)	
9902029	Lifter Pin (8"-14")		9902029	Lifter Pin (8"-14")	
1065700	Shim for Front Head/Standard .005" (.127mm)				
1065701	Shim for Front Head/Standard .010" (.254mm)				
1065702	Shim for Front Head/Standard .020" (.508mm)				
1065703	Shim for Standard/Footplate	2			
1065800	Shim (1½" Stroke) (Series VI, VIII & XI only)				
1066000	Set of Regular Inserts 5"				
1066100	Set of Regular Inserts 6"				
1066200	Set of Regular Inserts 7"				
1066300	Set of Regular Inserts 8"				
1066400	Set of Regular Inserts 10"				
1066500	Insert Screws	2 or 3			

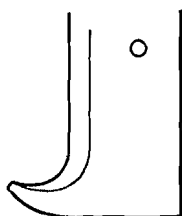

KLEEN-KUT INSERTS

Wolf pioneered Kleen-Kut inserts. They improve cutting through pile, knits, and all soft or loosely woven materials. As a result of their, clean shear cut, Kleen-Kut inserts help prevent unraveling and eliminates the packing or jamming of threads in the Footplate. All new Pacers, except the Jeans Machine™, have Kleen-Kut inserts installed at the factory since they are best for most types of cutting.

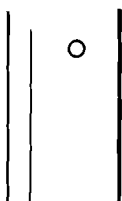

REGULAR INSERTS

Wolf's regular inserts are best for the cutting of demin and hard materials which do not unravel when cut. Regular inserts are more economical than Kleen-Kut inserts since they are reversible and cost less initially. Unless specifically ordered, regular inserts are not installed on new Pacers - except for the Jeans Machine™.

SERIES VI, VII & X Stone Sharpener

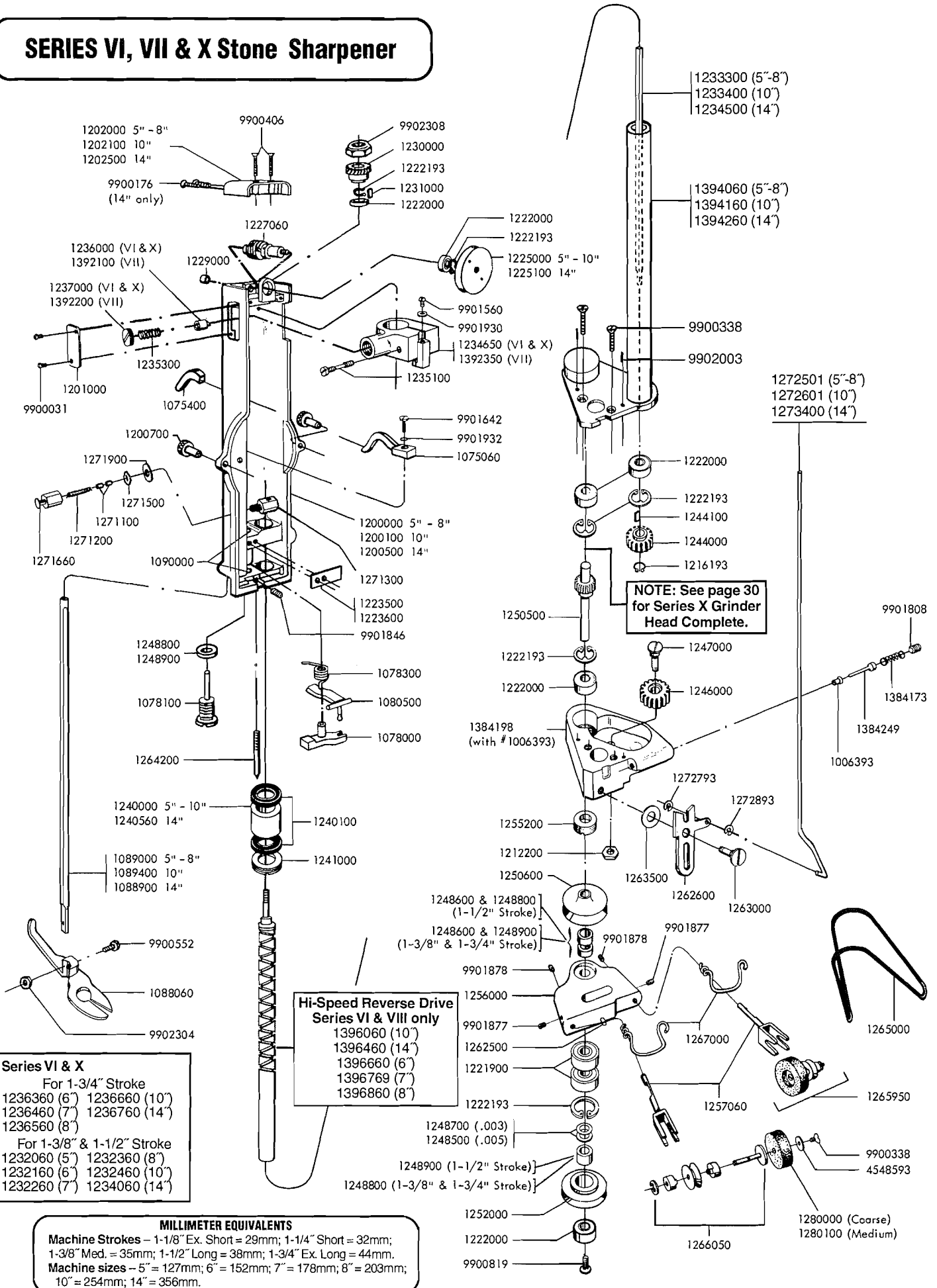

From the library of: Diamond Needle Corp

NUMBERS FOR SERIES VI, VII & X STONE SHARPENER

IN NUMERICAL ORDER

Part No.	Description	Quantity used if more than 1	Part No.	Description	Quantity used if more than 1
1006393	Bushing for Plunger		1267000	Locking Spring	2
1075060	Lift Hook		1271000	Tension Shoe	2
1075400	Lift Hook Cover		1271200	Tension Spring	
1078000	Unlocking Finger		1271300	Tension Shoe Container	
1078100	Footlock Pivot Pin		1271500	Locknut	
1078300	Footlock Pivot Spring		1271660	Tension Push Button Assembly	
1080500	Locking Cam		1271900	.050" (.381mm) Shim	
1088060	Presser Foot		1272501	Tension Rod (5"-8")	
1088900	14" Presser Foot Rod		1272601	Tension Rod (10")	
1089000	5"-8" Presser Foot Rod		1272793	Retaining Ring	
1089400	10" Presser Foot Rod		1272893	Grip Ring	
1090000	Bushing	2	1273400	Tension Rod (14")	
1200000	Sharpener Housing (5"-8")		1280000	Emery Wheel - Coarse	2
1200100	Sharpener Housing (10")		1280100	Emery Wheel - Medium	2
1200500	Sharpener Housing (14")		1384173	Spring	
1200700	Thumb Nut	2	1384198	Grinding Head with Bushing	
1201000	Cover Plate		1384249	Plunger	
1202000	Sharpener Housing (5"-8")		1392100	Follower (Series VII only)	
1202100	Sharpener Housing Cap (10"-Pacers before 1/89)		1392299	Retaining Nut (Series VII only)	
1202500	Sharpener Housing Cap		1392359	Follower Guide Assembly (Series VII only)	
1212200	Nut		1394060	Sharpener Tube S.A. (5"-8")	
1216193	Retaining Ring		1394160	Sharpener Tube S.A. (10")	
1221900	Bearing	2	1394260	Sharpener Tube S.A. (14")	
1222000	Bearing	6	1396060	10" Reverse Drive - Hi Speed	Series VI & VIII only.
1222193	Retaining Ring	6	1396460	14" Reverse Drive - Hi Speed	
1223500	Backplate Shim .005		1396660	6" Reverse Drive - Hi Speed	
1223600	Backplate Shim .010		1396760	7" Reverse Drive - Hi Speed	
1225000	Drive Pulley - Upper (5"-10")		1396860	8" Reverse Drive - Hi Speed	
1225100	Drive Pulley - Upper (14")		4548593	Emery Wheel Washer	2
1227060	Worm and Shaft Assembly		9900031	Cover Plate Screw	2
1229000	Bushing		9900176	Sharpener Cap Screw - 14" only	2
1230000	Worm Wheel Gear		9900338	Screw	4
1231000	Woodruff Key		9900406	Sharpener Cap Screw (all sizes)	2
1232060	5" Reverse Drive (1 1/8" & 1 1/2" Stroke)	Series VI & X only.	9900552	Presser Foot Screw	
1232160	6" Reverse Drive (1 1/8" & 1 1/2" Stroke)		9900819	Idler Pulley Screw	
1232260	7" Reverse Drive (1 1/8" & 1 1/2" Stroke)		9901560	Follower Guide Screw	
1232360	8" Reverse Drive (1 1/8" & 1 1/2" Stroke)		9901642	Lift Hook Screw	
1232460	10" Reverse Drive (1 1/8" & 1 1/2" Stroke)		9901808	Set Screw	
1233400	Drive Shaft (10")		9901846	Set Screw	
1234060	14" Reverse Drive (1 1/8" & 1 1/2" Stroke)		9901877	Set Screw	2
1234500	Drive Shaft (14")		9901878	Set Screw	2
1234650	Follower Guide Assembly - Series VI & X only		9901930	Washer	
1235100	Clamping Screw		9901932	Washer	
1235300	Spring		9902003	Roll Pin	2
1236000	Follower (Series VI & X only)		9902304	Stop Nut	
1236360	6" Reverse Drive (1 1/8" Stroke)	Series VI & X only.	9902308	Stop Nut	
1236460	7" Reverse Drive (1 1/8" Stroke)		Series X Sharpener Complete (1-1/2 Stroke)		
1236560	8" Reverse Drive (1 1/8" Stroke)		5"	Series X Sharpener Complete	1290057
1236660	10" Reverse Drive (1 1/8" Stroke)		6"	Series X Sharpener Complete	1290157
1236760	14" Reverse Drive (1 1/8" Stroke)	7"	Series X Sharpener Complete	1290257	
1240000	Bushing (5"-10")		8"	Series X Sharpener Complete	1290357
1240100	Wiper Ring	2	10"	Series X Sharpener Complete	1290457
1240560	Bushing (14")		14"	Series X Sharpener Complete	1290557
1241000	End Seal Nut		Series VI Sharpener Complete		
1244000	Driver Gear		5"	1-3/8" Stroke	1200857
1244100	Driver Gear Key		5"	1-1/2" Stroke	1200857
1246000	Idler Gear		6"	1-3/8" Stroke	1200957
1247000	Idler Gear Shaft		6"	1-1/2" Stroke	1200958
1248500	.005" (.127mm) Shim		6"	1-3/4" Stroke	1200959
1248600	Idler Pulley Space		7"	1-3/8" Stroke	1201257
1248700	.003" (.076mm) Shim		7"	1-1/2" Stroke	1201258
1248800	.060" (1.524mm) Spacer		7"	1-3/4" Stroke	1201259
1248900	.045" (1.143mm) Spacer		8"	1-3/8" Stroke	1201357
1250500	Gear Shaft		8"	1-1/2" Stroke	1201358
1250600	Drive Pulley		8"	1-3/4" Stroke	1201359
1252000	Idler Pulley		10"	1-3/8" Stroke	1201457
1255200	Bearing Locknut		10"	1-1/2" Stroke	1201458
1256000	Grinding Wheel Carriage		10"	1-3/4" Stroke	1201459
1257060	Grinder Arm S.A.	2	14"	1-3/8" Stroke	1201557
1262500	Shift Lever Pin		14"	1-1/2" Stroke	1201558
1262600	Shift Lever		14"	1-3/4" Stroke	1201559
1263000	Shoulder Screw				
1263500	Shim				
1264200	Centering Pin				
1265000	Drive Belt				
1265950	Shaft Assembly Complete with emery	2			
1266050	Shaft & Pulley S.A.	2			

SERIES VIII & XI Belt Sharpener

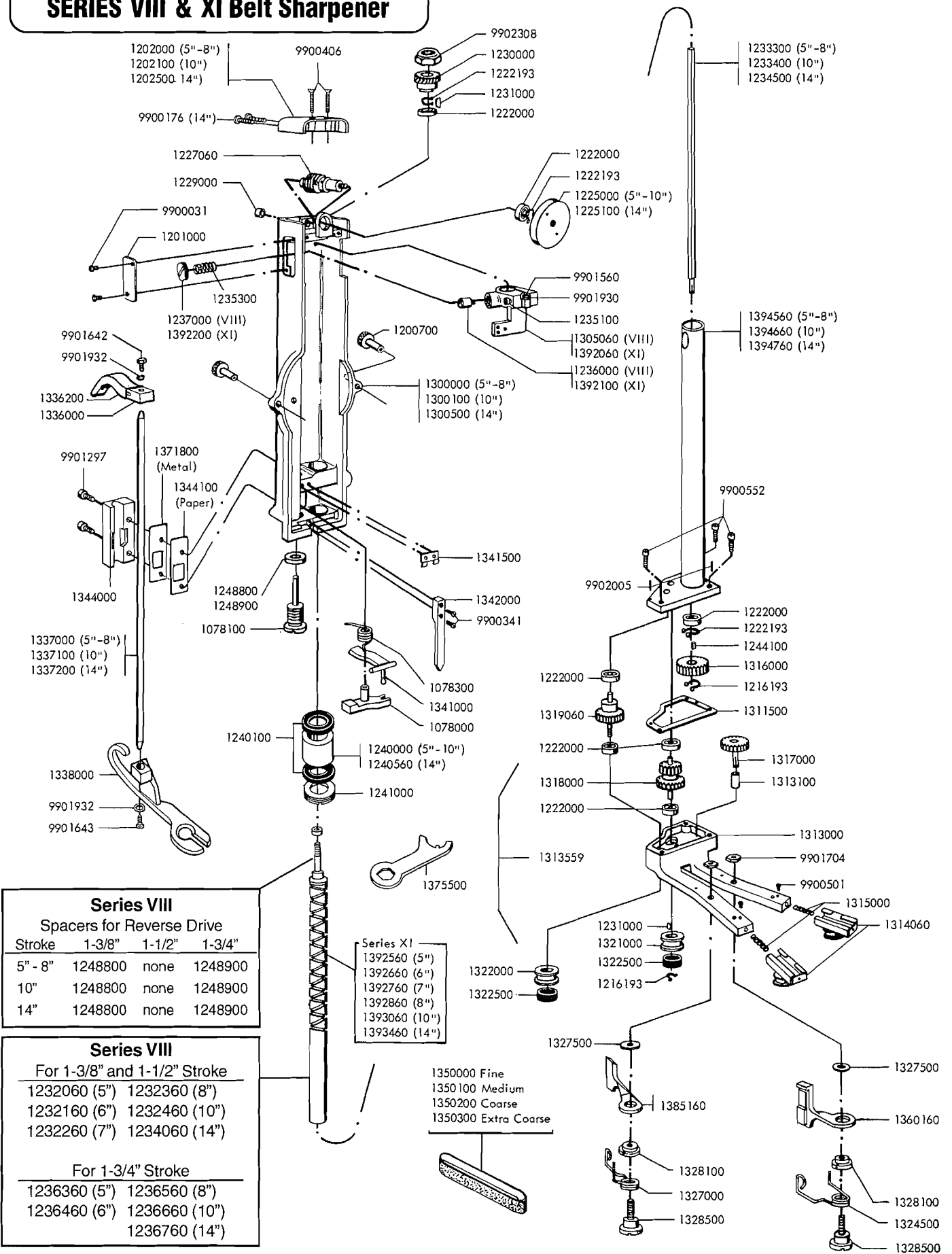

Series VIII			
Spacers for Reverse Drive			
Stroke	1-3/8"	1-1/2"	1-3/4"
5" - 8"	1248800	none	1248900
10"	1248800	none	1248900
14"	1248800	none	1248900

Series VIII	
For 1-3/8" and 1-1/2" Stroke	
1232060 (5")	1232360 (8")
1232160 (6")	1232460 (10")
1232260 (7")	1234060 (14")

For 1-3/4" Stroke	
1236360 (5")	1236560 (8")
1236460 (6")	1236660 (10")
	1236760 (14")

Series XI	
1392560	(5")
1392660	(6")
1392760	(7")
1392860	(8")
1393060	(10")
1393460	(14")

- 1350000 Fine
- 1350100 Medium
- 1350200 Coarse
- 1350300 Extra Coarse

Millimeter Equivalents	
Machine Strokes:	1-1/8" Ex. Short - 29mm; 1-1/4" Short - 32mm; 1-3/8" Med. - 35mm; 1-1/2" Long - 38mm; 1-2/4" Ex. Long - 44mm;
Machine Sizes:	5" - 127mm; 6" - 152mm; 7" - 178mm; 8" - 203mm; 10" - 254mm; 14" - 356mm.

From the library of: Diamond Needle Corp

BACKPLATE ASSEMBLY

ALL STONE SHARPENER SERIES
ALL BELT SHARPENER SERIES

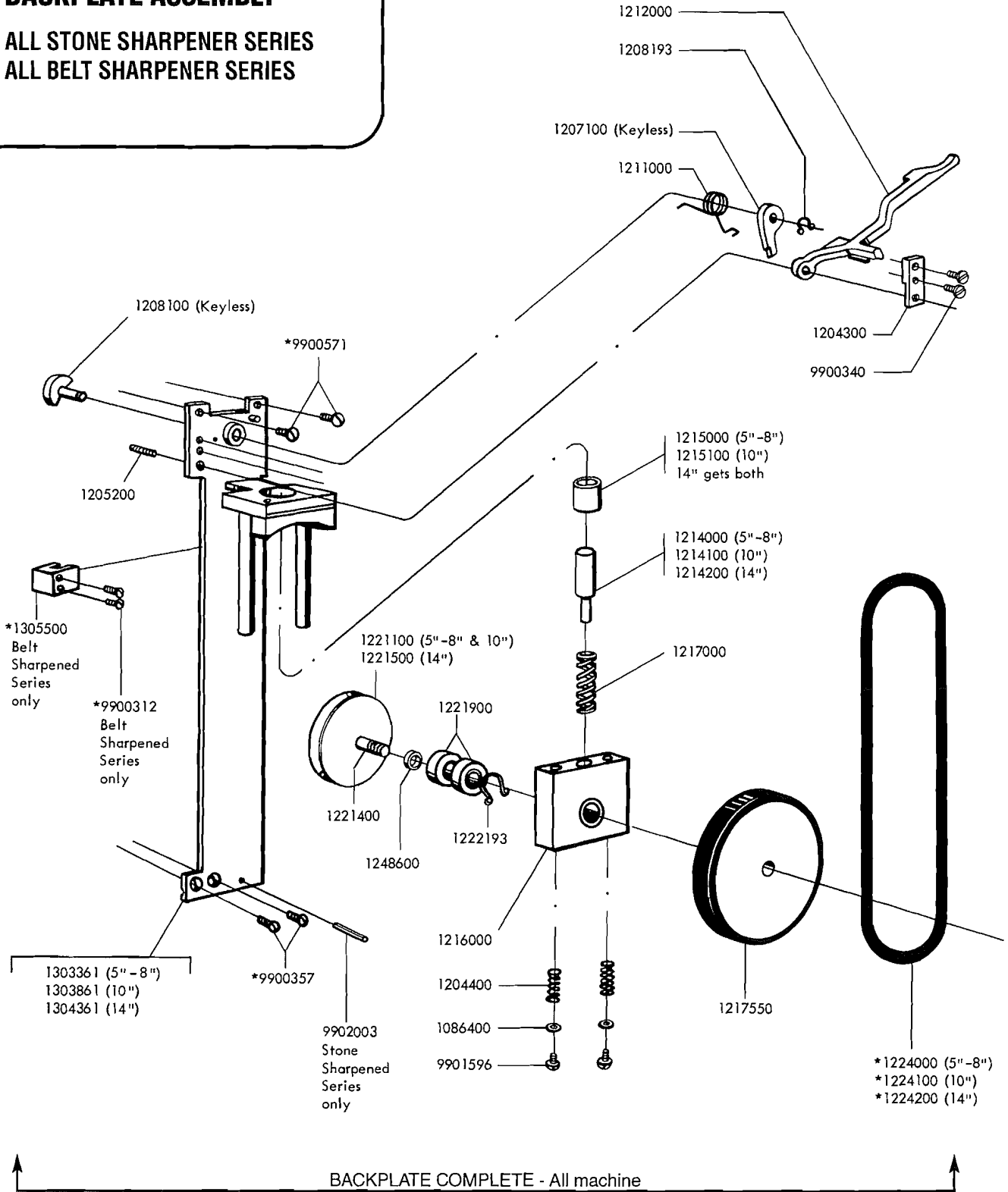

1303059 - 5" thru 8"
1303559 - 10"
1304059 - 14"

* NOT INCLUDED IN COMPLETE BACKPLATE

Millimeter Equivalents

Machine Strokes: 1-1/8" Ex. Short - 29mm; 1-1/4" Short - 32mm; 1-3/8" Med. - 35mm; 1-1/2" Long - 38mm; 1-2/4" Ex. Long - 44mm;
Machine Sizes: 5" - 127mm; 6" - 152mm; 7" - 178mm; 8" - 203mm; 10" - 254mm; 14" - 356MM.

NUMBERS FOR SERIES VIII & X BELT SHARPENER

IN NUMERICAL ORDER

Part No.	Description	Quantity used if more than 1	Part No.	Description	Quantity used if more than 1
1086400	Washer for 1204400	2	1221500	Drive Pulley - Lower 14"	
1204300	Starting Lever Support		1221900	Bearing	2
1204400	Spring Brake 5" - 10"	2	1222193	Retaining Ring	
1205200	Lever Pivot Screw		1224000	Upper Belt 5" - 8"	
1207100	Pawl - Keyless	— SOLD ONLY IN SETS	1224100	Upper Belt 10"	
1208100	Shaft - Keyless		1224200	Upper Belt 14"	
1208193	Retaining Ring		1248600	Spacer .120" (3.05mm)	
1211000	Pawl Spring		1303059	Backplate Complete Assembly 5" - 8"	
1212000	Starting Lever		1303361	Backplate S.A. 5" - 8"	
1214000	Actuating Pin 5" - 8"		1303559	Backplate Complete Assembly 10"	
1214100	Actuating Pin 10"		1303861	Backplate S.A. 10"	
1214200	Actuating Pin 14"		1304059	Backplate Complete Assembly 14"	
1215000	Bushing 5" - 8"	— 14" gets one of each	1304361	Backplate S.A.	
1215100	Bushing 10"		1305500	Nylon Guide - Belt Sharpened Series only	
1216000	Sliding Block		9900312	Nylon Guide Screw - Belt Sharpened Series only	2
1217000	Friction Wheel Spring		9900340	Lever Support Screw	2
1217550	Friction Wheel & Tire S.A.		9900357	Backplate Screw	2
1220000	Rubber Tire (Not Shown)		9900571	Backplate Mounting Screw	2
1221100	Drive Pulley - Lower 5" - 8" & 10"		9901596	Sliding Block Screw	2
1221400	Pulley Shaft		9902003	Roll Pin - Stone Sharpened Series only	

Millimeter Equivalents

Machine Strokes: 1-1/8" Ex. Short - 29mm; 1-1/4" Short - 32mm; 1-3/8" Med. - 35mm; 1-1/2" Long - 38mm; 1-2/4" Ex. Long - 44mm;
Machine Sizes: 5" - 127mm; 6" - 152mm; 7" - 178mm; 8" - 203mm; 10" - 254mm; 14" - 356MM.

PACER STATOR BLANKS

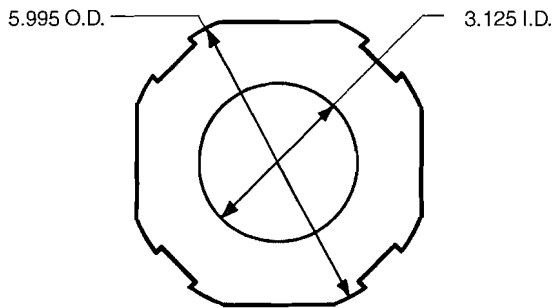

PACER 100

13710XX - Super & Jeans Machine
13711XX - Junior
13712XX - Two Speed

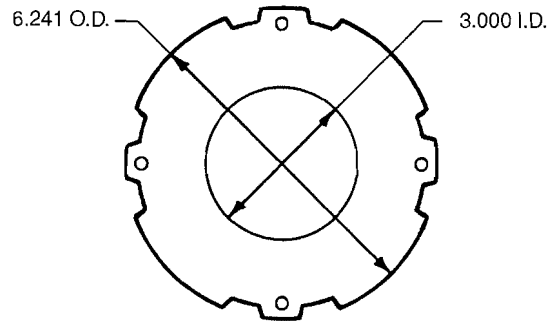

2001100 - Junior

1001200 - Super, Jeans Machine & Two Speed

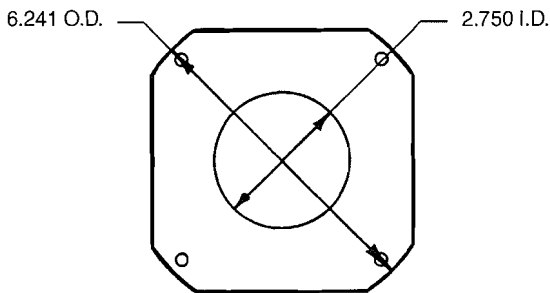

INTERIM

2031100 - Junior
1001300 - Super, Jeans Machine & Two Speed

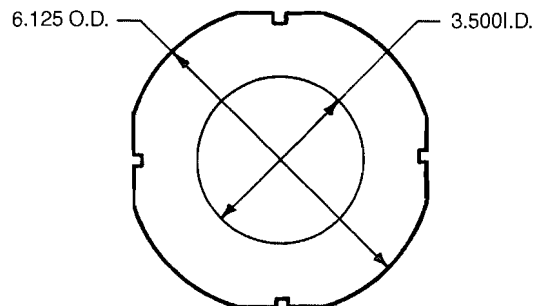

1011200 - Super & Jeans Machine
2011100 - Junior

3011100 - Super Jeans & Super Series J

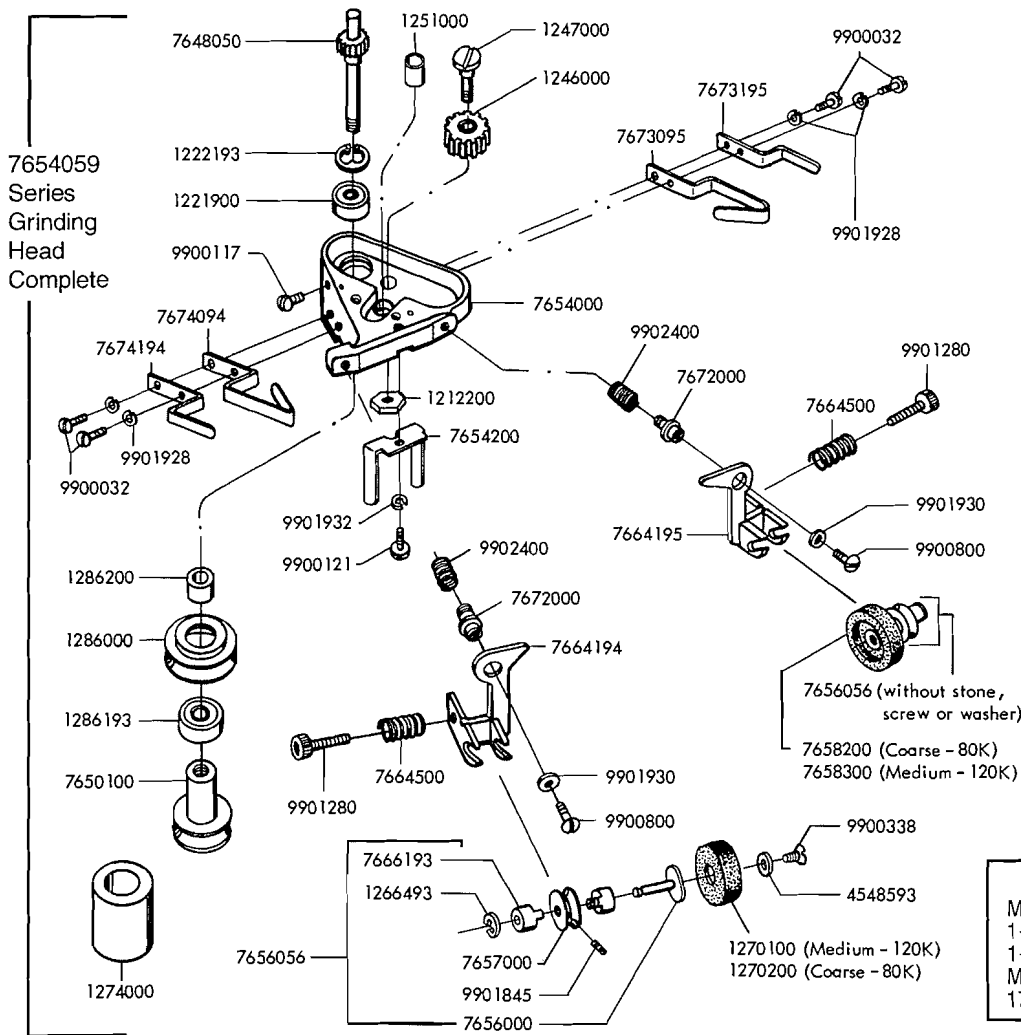

SERIES X SHARPENER

Grinding Head only, See page 26 for Sharpener Housing, Reverse Drive, Sharpener Tube and related parts.

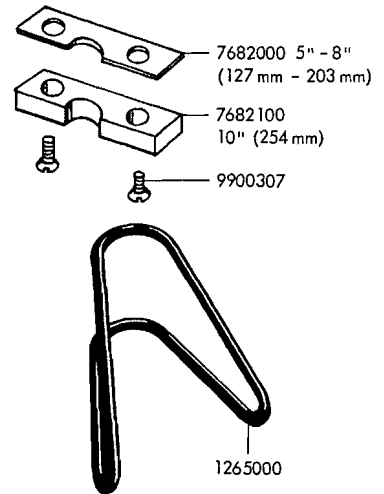

Millimeter Equivalents

Machine Strokes: 1-1/8" Ex. short, 29mm; 1-1/4" Short, 32mm; 1-3/8" Med., 35mm; 1-1/2" Long, 38mm; 1-3/4" Ex. long, 44mm.
 Machine Sizes: 5" - 127mm; 6" - 152mm; 7" - 178mm; 8" - 203mm; 10" - 254mm; 14" - 365mm.

SERIES X Sharpener Installation Instructions

If your PACER is supplied with the option SERIES 'X' style grinder head, this page gives you the necessary parts listings.

If you desire to change over a regular WOLF Pacer VI to a Pacer SERIES 'X' ... in other words use the Series 'X' grinder head as opposed to the regular Pacer style. You must order six (6) parts as follows: One 7654059 - Grinder Head Complete; One 1274000 Presserfoot Rod Bushing Complete; One 10"-7682100 or 8" -

7682000 Wear Plate (specify size); 1305060 Follower Guide Assy (not shown); 1305500 Guide and (2) 9900312 Screws.

To install the Series X grinder head on a Pacer it is necessary to drill the bottom of the sharpener housing (1200000) to accommodate the wear plate. It is also necessary to install the new part spacer on to the presserfoot rod just above the presserfoot to prevent the grinding wheels from rubbing on the presserfoot.

Part No.	Description	Quantity used if more than 1
1212200	Hex Nut - Thin	
1221900	Bearing	
1222193	Retaining Ring	
1246000	Idler Gear	
1247000	Idler Gear Shaft	
1251000	Bushing (for Presserfoot Rod)	
1265000	Drive Belt	
1266493	Retaining Ring	
1270100	1" (25.4mm) Emery Wheel (Medium - 120 K)	
1270200	1" (25.4mm) Emery Wheel (Coarse - 80K)	
1274000	Presserfoot Bushing	
1286000	Idler Pulley	
1286193	Bearing	
1286200	Spacer - Idler Pulley	
4548593	Emery Wheel Washer	
7648050	Gear Shaft Assembly	
7650100	Drive Pulley	
7654000	Housing - Grinding Head	
7654200	Stop Bracket	
7656000	Grinding Wheel Shaft	
7656056	Shaft & Pulley S.A.	2
7657000	Pulley	
7658200	1-3/8" (34.9mm) Emery Wheel (Coarse-80K)	
7658300	1-3/8" (34.9mm) Emery Wheel (Medium-120K)	

Part No.	Description	Quantity used if more than 1
7664194	Grinding Wheel Arm - S.A. - L.H.	
7664195	Grinding Wheel Arm - S.A. - R.H.	
7664500	Adjusting Spring	2
7666193	Bronze Bushing	2
7672000	Stud 2	
7673095	Support Spring - Inner - R.H.	
7673195	Outer Pressure Spring - R.H.	
7674094	Support Spring - L.H. - Inner	
7674194	Outer Pressure Spring - L.H.	
7682000	Wear Plate 5" - 8" (127mm - 203mm)	
7682100	Wear Plate 10" (254mm)	
7693000	Gasket (Not shown)	
9900032	Screw	2
9900117	Screw	
9900121	Screw	
9900307	Flat Head Screw	2
9900338	Flat Head Screw	2
9900800	Pan Head Screw	2
9901280	Socket Head Cap Screw	2
9901845	Socket Head Set Screw	
9901928	Lock Washer	4
9901930	Lock Washer	2
9901932	Lock Washer	
9902400	Heli-Coil Insert	2

KNIVES

TYPES & SIZES OF VARIOUS WOLF KNIVES



REGULAR



WAVE*

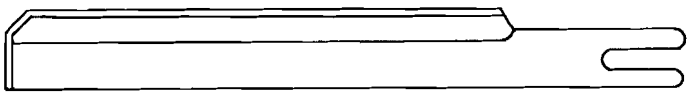

DURO TIP

SIZE	LENGTH	MATERIAL	REGULAR	WAVE*	DURO TIP
5" (127mm)	6-15/16" (176.2mm)	Carbon Steel	1400170	1405170	———
		High Speed Steel	1401171	1406171	1421171
		Teflon Coated	1402171	1407172	———
6" (152mm)	7-15/16" (201.6mm)	Carbon Steel	1400270	1405270	———
		High Speed Steel	1401271	1406271	1421271
		Teflon Coated	1402272	1407272	———
7" (178mm)	8-15/16" (227mm)	Carbon Steel	1400370	1405370	———
		High Speed Steel	1401371	1406371	1421371
		Teflon Coated	1402372	1407372	———
8" (203mm)	9-15/16" (252.4mm)	Carbon Steel	1400470	1405470	———
		High Speed Steel	1401471	1406471	1421471
		Teflon Coated	1402472	1407472	———
10" (254mm)	11-3/4" (298.4mm)	Carbon Steel	1400570	———	———
		High Speed Steel	1401571	1406571	1421571
		Teflon Coated	1402572	1407572	———
14" (356mm)	14-13/16" (376.2mm)	Carbon Steel	———	———	———
		High Speed Steel	1401671	1406671	———
		Teflon Coated	1402672	1407672	———

PLEASE NOTE:

Duro Tip knives are 1/16" (1.59mm) longer than others.
Knives not stocked require 10 weeks delivery.

* When using Wave Blade – Part #1328100 - Eccentric Shoulder Bushing slot (must) be pointing to the back of machine. (See illustration shown on page 13.)

ACCESSORIES

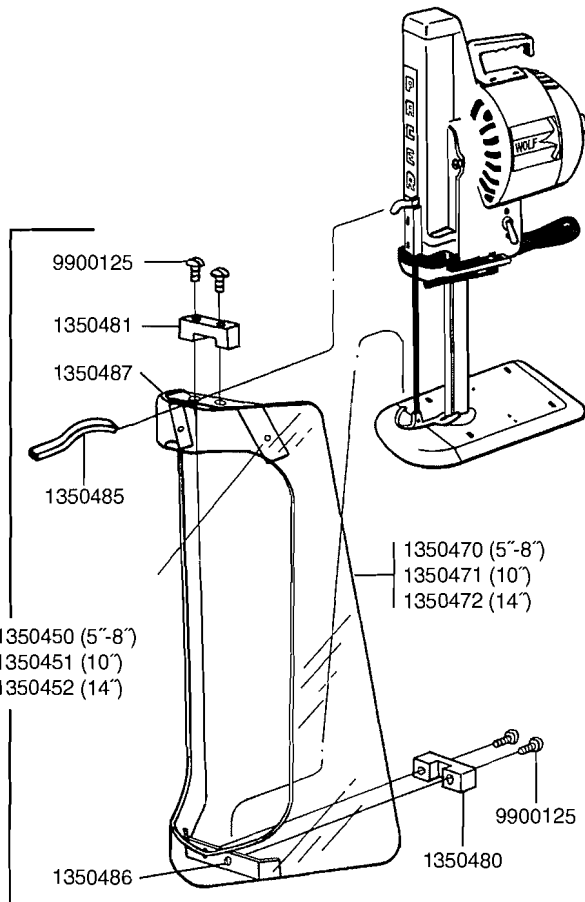

PACER GUARD

Part No.	Description	Quantity used if more than 1
1350450	Guard Complete (5"-8")	
1350451	Guard Complete (10")	
1350452	Guard Complete (14")	
1350470	Straight Knife Guard - Pacer (5"-8")	
1350471	Straight Knife Guard - Pacer (10")	
1350472	Straight Knife Guard - Pacer (14")	
1350480	Clamp - Lower	
1350481	Clamp - Upper	
1350485	Lift Hook	
1350486	Lower Support Bracket	
1350487	Upper Support Bracket	
9900119	Screw #8-32 x 1/4 RHMS	4
9900124	Screw #8-32 x 5/8 RHMS	2
9900125	Screw #8-32 x 3/4 RHMS	2

INSTALLATION OF THE PACER GUARD

1. Remove upper and lower clamps from supports if assembled.
2. Place guard underneath the presserfoot rod lift hook and on the top put on upper clamp and screws.
3. Guard handle slides between clamp and the lift hook.
4. Install lower clamp on the back of the presserfoot and tighten all screws.

WOLF PACER SPARE PARTS KITS

Recommended spare parts for one Pacer, for one year, Kits include: medium stones or belts, Kleen

Kut inserts, high speed steel knives, regular switch, upper belts, rubber tire and circuit breakers.

2450001	5"	PACER VII	1/50	2450013	7"	PACER VII	1/50	2450025	10"	PACER VII	1/50
2450002	5"	PACER VII	1/60	2450014	7"	PACER VII	1/60	2450026	10"	PACER VII	1/60
2450003	5"	PACER VII	3 PH	2450015	7"	PACER VII	3 PH	2450027	10"	PACER VII	3 PH
2450004	5"	PACER XI	1/50	2450016	7"	PACER XI	1/50	2450028	10"	PACER XI	1/50
2450005	5"	PACER XI	1/60	2450017	7"	PACER XI	1/60	2450029	10"	PACER XI	1/60
2450006	5"	PACER XI	3 PH	2450018	7"	PACER XI	3 PH	2450030	10"	PACER XI	3 PH
2450007	6"	PACER VII	1/50	2450019	8"	PACER VII	1/50	2450031	14"	PACER VII	1/50
2450008	6"	PACER VII	1/60	2450020	8"	PACER VII	1/60	2450032	14"	PACER VII	1/60
2450009	6"	PACER VII	3 PH	2450021	8"	PACER VII	3 PH	2450033	14"	PACER VII	3 PH
2450010	6"	PACER XI	1/50	2450022	8"	PACER XI	1/50	2450034	14"	PACER XI	1/50
2450011	6"	PACER XI	1/60	2450023	8"	PACER XI	1/60	2450035	14"	PACER XI	1/60
2450012	6"	PACER XI	3 PH	2450024	8"	PACER XI	3 PH	2450036	14"	PACER XI	3 PH

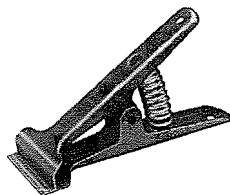

CLOTH CLAMP

GOOSENECK LAMP

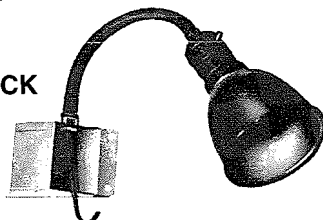

Part No.	Description
1045200	Goose Neck Lamp
1045400	Shade
1103250	1 Phase Line Cord (25 feet)
1104050	3 Phase Line Cord (25 feet)
1123000	20 Feet of Coiled Cord
2100000	Cloth Clamp

NOTE:
NOT ALL ITEMS LISTED ARE SHOWN

MILLIMETER EQUIVALENTS

Machine Strokes - 1-1/8" Ex. Short = 29mm; 1-1/4" Short = 32mm;
1-3/8" Med. = 35mm; 1-1/2" Long = 38mm; 1-3/4" Ex. Long = 44mm.
Machine sizes - 5" = 127mm; 6" = 152mm; 7" = 178mm; 8" = 203mm;
10" = 254mm; 14" = 356mm.

ACCESSORIES

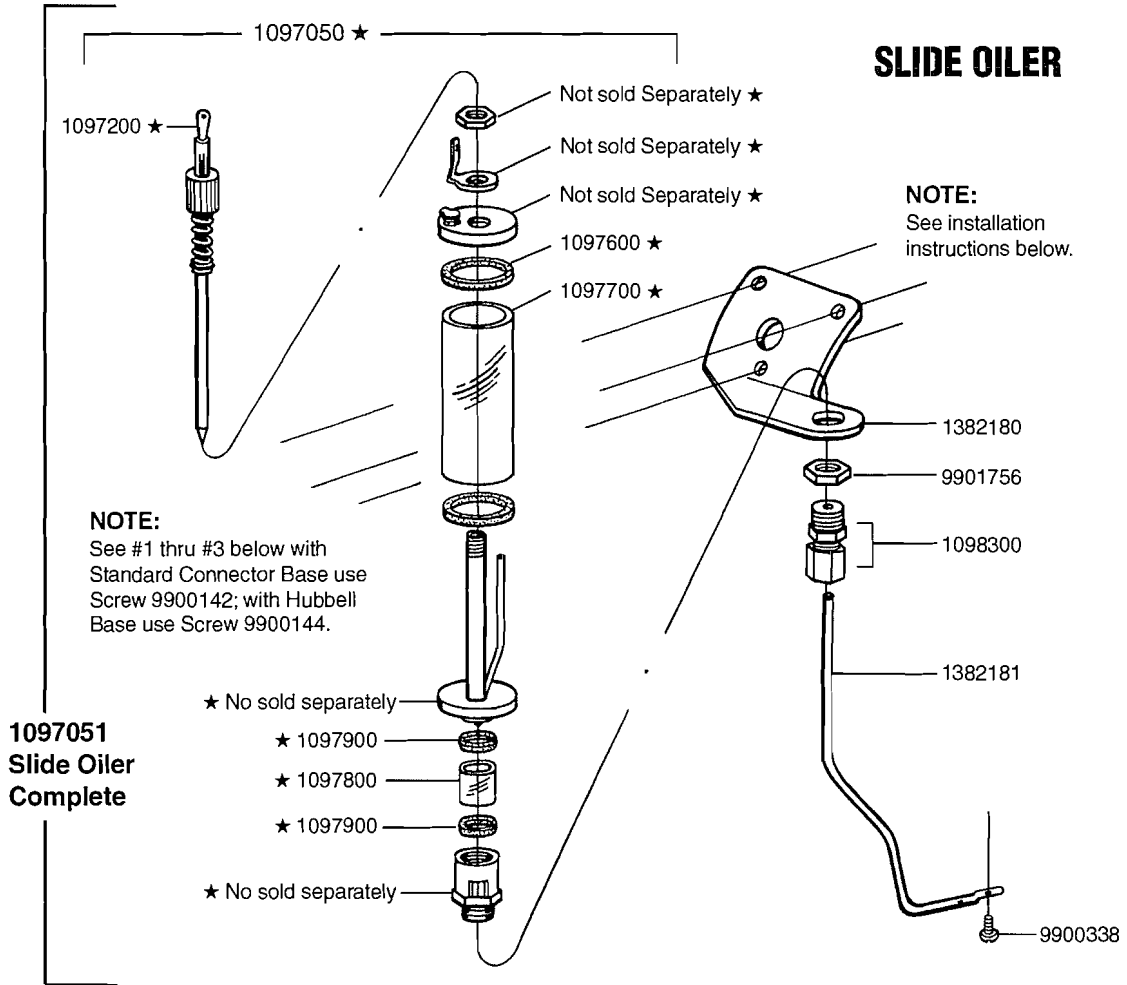

Part No.	Description	Quantity used if more than 1	Part No.	Description	Quantity used more than 1
1097050	Slide Oiler Assy. (Parts marked with ★)		1098300	Connector	
1097051	Slide Oiler Complete (W/Bracket & Tube)		1382180	Oiler Bracket	
1097200	Stem Sub. Assy. Complete		1382181	Oiler Tube	
1097600	Body Washer		9900142	3/8" Lg. Screw (Standard Connector)	3
1097700	Body Glass		9900144	1/2" Lg. Screw (Hubbell Connector)	3
1097800	Tube Glass		9900338	6-32 x 5/16 Flat Head Screw	
1097900	Sight Feed Gasket		9901756	1/2-20 Elastic Half Nut	

INSTALLATION OF THE SLIDE OILER

1. Disconnect electrical power.
2. Remove connector base and place bracket underneath. To do this the wiring will have to be disconnected from the connector and wires run through the bracket.
3. Rewire electrical connector and screw down on bracket with screws provided.
4. Remove bottom portion from oiler and place oiler in the bracket. Screw on large nut to hold in place.
5. Slide nut and little sleeve on to oiler tube. Connect this bottom portion of oiler removed in Step #4.
6. Connect tube and bottom portion to oiler body.
7. Fasten tube down underneath drip pan with screw provided.

Millimeter Equivalents

Machine Strokes: 1-1/8" Ex. Short - 29mm; 1-1/4" Short - 32mm; 1-3/8" Med. - 35mm; 1-1/2" Long - 38mm; 1-2/4" Ex. Long - 44mm; Machine Sizes: 5" - 127mm; 6" - 152mm; 7" - 178mm; 8" - 203mm; 10" - 254mm; 14" - 356MM.

ACCESSORIES TWIN FLOW WETTER

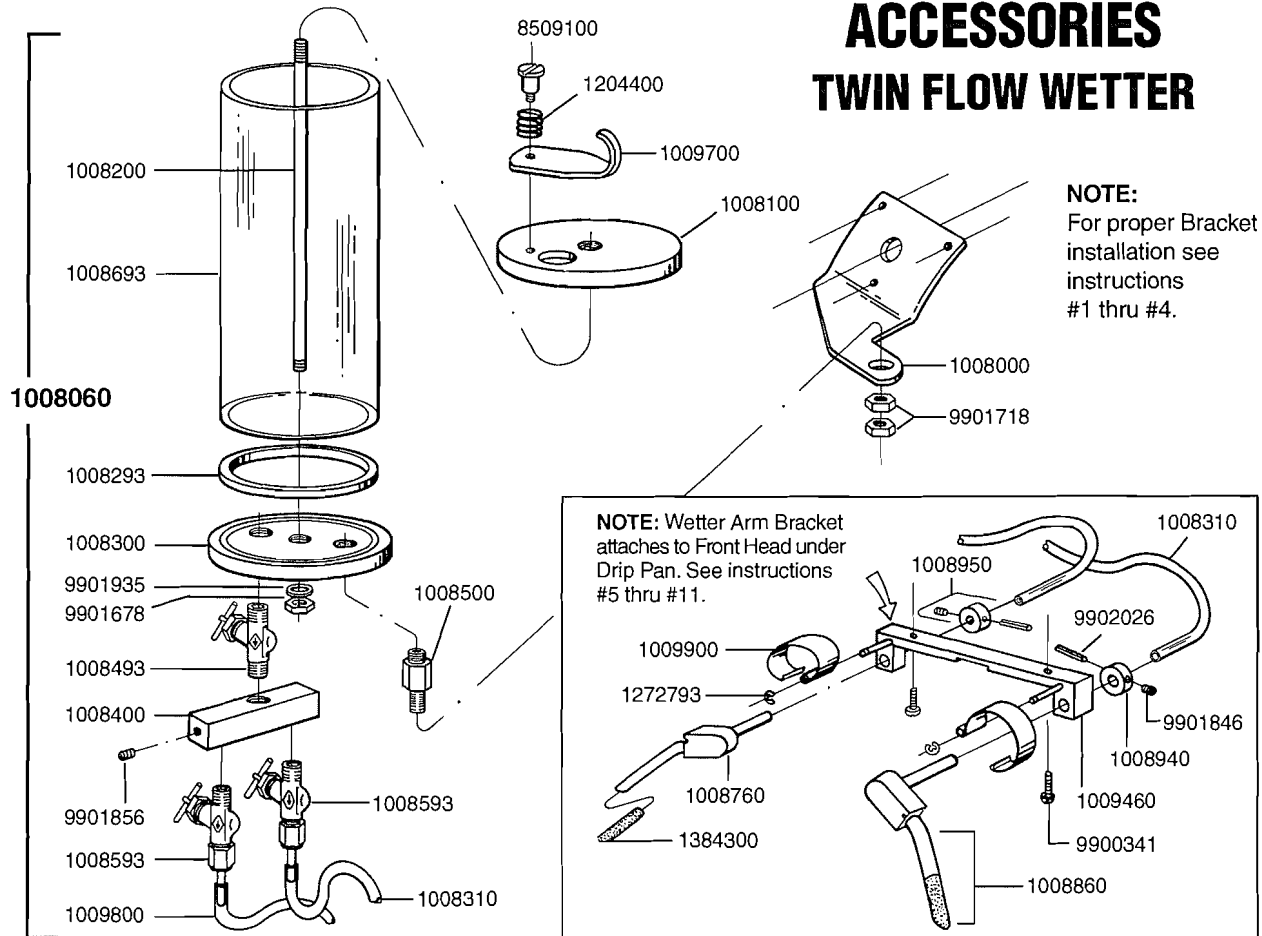

Part No.	Description	Quantity used if more than 1	Part No.	Description	Quantity used more than 1
1008000	Wetter Mounting Bracket		1009460	Wetter Arm Bracket	
1008060	Twin Flow Wetter Assembly Complete		1009700	Lid	
1008100	Wetter Top		1009800	Hose Connector	2
1008200	Connecting {Post		1009900	Wetter Arm Spring	2
1008293	'O' Ring		1204400	Spring	
1008300	Wetter Bottom		1272793	Retaining Ring	2
1008310	Rubber Tube		1384300	Felt Pad	2
1008400	Valve Block		8509100	Shoulder Screw	2
1008493	Valve-Shut Off		9900341	Screw	2
1008500	Mounting Stud		9901678	Nut	
1008593	Valve - Control		9901718	Jam Nut	2
1008693	Wetter Body		9901846	Socket Set Screw	2
1008760	Wetter Arm S.A. - Right Hand		9901856	Socket Set Screw	
1008860	Wetter Arm S.A. - Left Hand		9901935	Lock Washer	
1008940	Stop Collar	2	9902026	Roll Pin	2
1008950	Wetter Arm Stop	2			

INSTALLATION OF THE WETTER*

1. Disconnect electrical power.
2. Remove connector base from machine and disengage wiring from connector base.
3. Thread wires through wetter bracket of wetter assembly and place assembly on machine.
4. Reattach wires to connector and screw connector base down on machine with wetter assembly bracket underneath, using screws supplied with assembly.
5. Unscrew #1200700, thumb nuts and remove sharpener housing.
6. Insert knife bolt wrench, #1092000, and loosen the knife bolt #1064050. Remove the knife through the bottom of the footplate being careful of knife's sharp edge.
7. Remove two (2) bottom drip pan screws, #9900337.
8. The wetter arm bracket, #1009460, will mount under the drip pan with the screws provided, #9900341.
9. Replace blade and check alignment of wetter arms against blade.
10. Open arms and replace sharpener.
11. Flash start machine and recheck rotation of motor. If its running in proper direction, engage sharpener one time to test.
12. Mount wetter on bracket and secure with jam nuts #1008099, then connect rubber tubes #1008310 to wetter arms.
13. Fill tank with 1 part Custol - 16 parts water.
14. Check flow of formula to blade and adjust for proper amount.

* For Series VII only and recommended for 6" Pacers.

ACCESSORIES

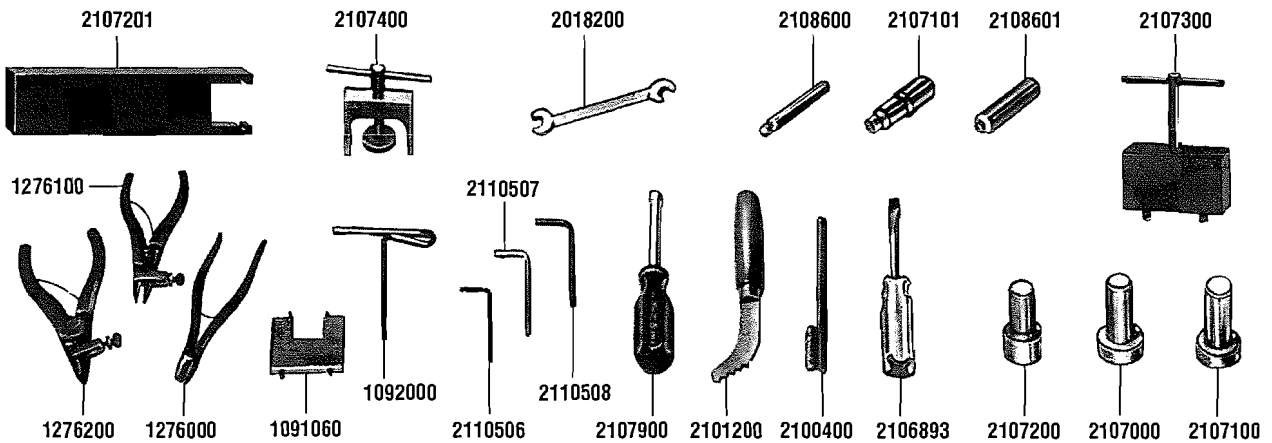

TOOLS

- 1091060 Pin Wrench for #1053000 and #1225000
- 1092000 Knife Wrench
- 1276000 Pliers – Internal Snap Ring
- 1276100 Pliers – External Snap Ring
- 1276200 Pliers – External Snap Ring
- 2101200 Slot Cleaner
- 2101400 Wire Brush
- 2106893 Screwdriver
- 2107000 Bearing Knocker for Front Motor Bearing (In)

- 2107100 Bearing Knocker for Rear Motor Bearing (In)
- 2107101 Bearing Knocker for Rear Motor Bearing (Out)
- 2107200 Bearing Knocker for Crank Bearing (In)
- 2107201 Belt Pressure Arm Tool
- 2107300 Crank Wrench
- 2107400 Crank Bearing Puller
- 2107500 Open End Wrench
- 2107600 Follower Tool
- 2107900 Nut Driver 1/4"

- 2108600 Bearing Knocker for #1221900 & #1222000 (Out)
- 2108601 Bearing Knocker for #1221900 & #1222000 (In)
- 2109000 Front Head Bearing Puller
- 2109100 Driver for #1227060 Shaft Assy
- 2109850 Pacer Tool Kit
- 2109970 Knocker for Bushing #1006393
- 2110506 3/32 Allen Wrench
- 2110507 7/64 Allen Wrench
- 2110508 1/8 Allen Wrench
- 2110950 Salesman Tool Kit

LUBRICANTS & CLEANING AGENTS

KEEP-M-KLEEN Emery Wheel Cleaner

This is a spray-on solution which keeps sharpening wheels working at peak efficiency. It also is excellent for cleaning guides and other parts.

ORDER WOLF .. #2100600

CUTSOL

A special formula wetting agent for cutting synthetic and fusible fabrics. Please note, Cutsol is furnished in a concentrate and must be mixed a 1 part Cutsol to 16 parts water.

**ORDER WOLF
#2101100 One Gallon**

OIL and GREASE

ORDER WOLF

**#2101500 Bottle of Oil
#2101600 Grease**

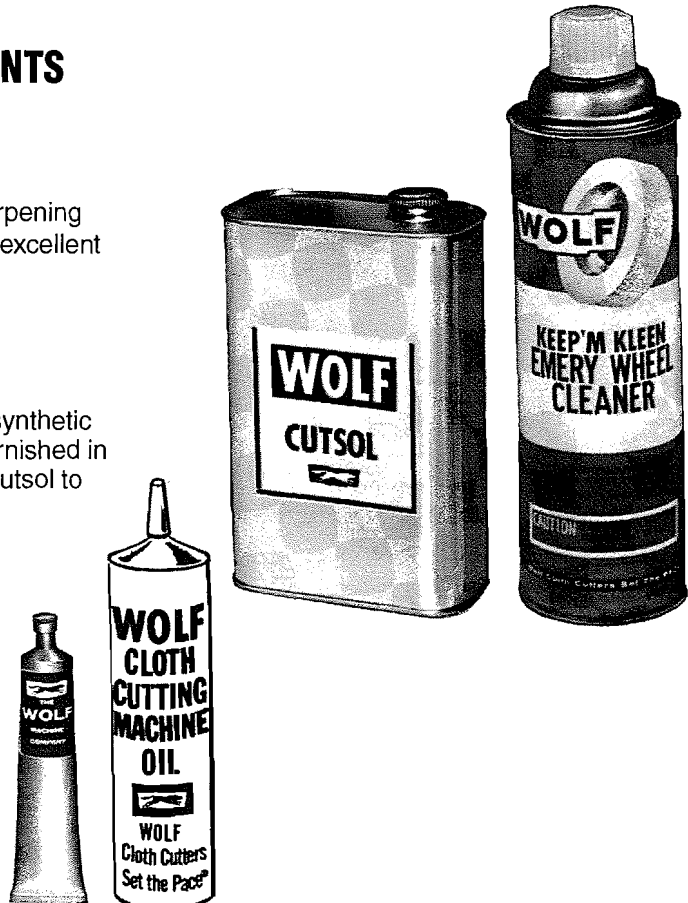

Wolf Straight Knife Specifications for –

Pacer 100; 2 Speed 100; Jeans M 100; Super J 100; Jr. 100

MODELS	Motor: 1 Phase ★ 3 Phase ● Horsepower Idle			Horsepower Under Load (Approx.)		1 Phase ★ 3 Phase ● Voltages Available				Cycle: 50▲ / 60 ■ Stroke Recommended Inches (Centimeters)			
	1/3	1	1.5	★	●	110 VT	220 VT	240 VT	380 VT	1½ (3.2)	1¾ (3.5)	1¾ (3.8)	1¾ (4.4)
Pacer '100'	★●			1.2	1.4	★	★●	★●	●			▲	■
Dual Speed	★●			1.0	1.2	★	★●			▲	▲	■	
Jeans Regular	★●			1.2	1.4	★	★						▲■
Super		●		1.2	1.85		●		●				▲■
Super Series J		●		1.85		●		●					▲■
Pacer Junior	★●			.65	.65	★	★●	★	●		▲	■	

MODELS	5" (12.7)	6" (15.2)	7" (17.8)	8" (20.3)	10" (25.4)	14" (35.8)	Approximate Weight Pounds (Kilograms)
Blade Length:	5" (12.7)	6" (15.2)	7" (17.8)	8" (20.3)	10" (25.4)	14" (35.8)	
Cut Capacity:	4" (10.1)	5" (12.7)	6" (15.2)	7" (17.8)	8.5" (21.5)	12.5" (30.9)	
Pacer 100	✓	✓	✓	✓	✓	✓	30 lbs. (13.6kg)
Dual Speed	✓	✓	✓	✓	✓		33 lbs. (15.0 kg)
Jeans Machine	✓	✓	✓	✓	✓		30 lbs. (13.6kg)
Super Series J	✓	✓	✓	✓	✓		31 lbs. (14.1kg)
Pacer Junior	✓	✓	✓	✓			18 lbs. (8.2kg)

MODELS	Sharpener Recommended		Emery Grade Recommended				Blade Recommended			
	Stone	Belt	Fine	Medium	Coarse	X-Coarse	Regular	Duro	Wave	Notch
Pacer 100	✓	✓	✓	✓	✓		✓	✓		
Dual Speed	✓	✓	✓	✓	✓		✓		✓	✓
Jeans Machine		✓		✓	✓	✓	✓			
Super Series J		✓			✓	✓	✓			
Pacer Junior	✓	✓	✓	✓			✓	✓		

Pacer; 2 Speed; Jeans Machine; Super J; Junior

MODELS	Motor: 1 Phase ★ 3 Phase ● Horsepower Idle			Horsepower Under Load (Approx.)		1 Phase ★ 3 Phase ● Voltages Available				Cycle: 50▲ / 60 ■ Stroke Recommended Inches (Centimeters)			
	1/3	1	1.5	★	●	110 VT	220 VT	240 VT	380 VT	1½ (3.2)	1¾ (3.5)	1¾ (3.8)	1¾ (4.4)
Pacer '100'	★●			1.2	1.4	★	★●	★●	●			▲	■
Dual Speed	★●			1.0	1.2	★	★●			▲	▲	■	
Jeans Regular	★●			1.2	1.4	★	★						▲■
Super		●		1.2	1.85		●		●				▲■
Super Series J		●		1.85		●		●					▲■
Pacer Junior	★●			.5	.5	★	★●	★	●		▲	■	

MODELS	5" (12.7)	6" (15.2)	7" (17.8)	8" (20.3)	10" (25.4)	14" (35.8)	Approximate Weight Pounds (Kilograms)
Blade Length:	5" (12.7)	6" (15.2)	7" (17.8)	8" (20.3)	10" (25.4)	14" (35.8)	
Cut Capacity:	4" (10.1)	5" (12.7)	6" (15.2)	7" (17.8)	8.5" (21.5)	12.5" (30.9)	
Pacer 100	✓	✓	✓	✓	✓	✓	35 lbs. (15.9kg)
Dual Speed	✓	✓	✓	✓	✓		38 lbs. (17.0 kg)
Jeans Machine	✓	✓	✓	✓	✓		35 lbs. (15.9g)
Super Series J	✓	✓	✓	✓	✓		36 lbs. (16.3kg)
Pacer Junior	✓	✓	✓	✓			23 lbs. (10.5kg)

MODELS	Sharpener Recommended		Emery Grade Recommended				Blade Recommended			
	Stone	Belt	Fine	Medium	Coarse	X-Coarse	Regular	Duro	Wave	Notch
Pacer 100	✓	✓	✓	✓	✓		✓	✓		
Dual Speed	✓	✓	✓	✓	✓		✓		✓	✓
Jeans Machine		✓		✓	✓	✓	✓			
Super Series J		✓			✓	✓	✓			
Pacer Junior	✓	✓	✓	✓			✓	✓		

WOLF PACER GUARANTEE

We guarantee our machines for six months from the date of invoice against defective parts and workmanship. We will repair or replace any machine covered by this guarantee when returned to us freight charges prepaid. This guarantee does not cover machines damaged by misuse or neglect and is void if any parts other than genuine Wolf parts are used in or on the machine.

WOLF®

5570 CREEK ROAD, CINCINNATI, OHIO 45242 / U.S.A.

1st/Since 1888

TOLL FREE 1-800-543-WOLF

Phone: 513-791-5194 / FAX 513-791-0925

e-mail: info@wolfmachine.com • Web Site: www.wolfmachine.com